

Automotive



victron energy
BLUE POWER



Energy. Anytime. Anywhere.



INDEX

Introduction	4
Application examples	5
Motorhomes	6
Ambulances	10
Electric coffee cart	14
Systems	16
Accessories	20
Technical information	22
About Victron Energy	90



Automotive

The automotive market comprises a broad range of applications requiring a reliable power supply. In vehicles such as fire engines, ambulances and police cars a human life may depend on an autonomous system. So it is vital that all systems function flawlessly. Victron Energy offers you such an answer. We are proud to offer you our modern translation for freedom and independence. Energy. Anytime. Anywhere.

Autonomous systems

Our products are being used in all vehicles requiring an extra power supply, for example ambulances, firetrucks, police cars, motor homes, service vehicles, luxurious horse trailers, military vehicles and broadcasting vehicles.

Energy. Anytime. Anywhere.





Motorhomes



Ambulances



Coffee cart

Motorhomes

Australia - SLR Caravan & Motorhomes

On adventure with a motorhome

For those who are looking for real adventure during their vacation, proper equipment and good transport are the basic needs. The Australian company 'SLR Caravans & Motorhomes' builds four wheel drive motor homes, expedition vehicles and caravans, especially made to withstand harsh Australian conditions.

Adventurer

The most advanced vehicle for extreme conditions is the Adventurer 4x4 motorhome/expedition from SLR. This vehicle is the gateway to spectacular and usually inaccessible destinations all over the globe. Thanks to the purpose designed and engineered body, the Adventurer is capable of tackling tough terrain such as the desert, rivers, mountains and sandy roads.









Victron Energy equipment

An almost indispensable option for the off-road vehicles is the Victron Phoenix MultiPlus: a powerful true sine wave inverter. In the event of generator power being disconnected, the inverter within the Multi is automatically activated and takes over the supply to the connected loads. So even in the middle of nowhere the off-road vehicles are assured of a reliable power supply.

The inverter converts 12 Volt power to 240 Volt power, which can be used for appliances such as the air conditioner, microwave, washing machine, refrigeration compressor, etc. The higher Watt units provide even more 'start up power', which is generally required by these appliances.

Ambulances

Paris, France: Power supply guaranteed for Paris ambulances

The company Petit Picot has installed MultiPlus 12/1600/70 in ambulances in the Parisian region. The MultiPlus provides a pure sinusoidal 230 volt alternating current power supply for the different medical devices (incubators, monitors, defibrillators, etc.) on board. These important medical devices need to be operational at all times. The MultiPlus UPS function provides the ambulances a 230Vac

permanent power supply. So an ambulance can function whether it is connected to the mains when idle or in autonomous mode when driving.

With the MultiPlus on board it has been possible to simplify wiring, compared with a separately installed inverter and charger, with the consequent cost saving in the installation.









Global market leader in ambulances

Victron Energy is global market leader in power supply equipment for ambulances. Our products are considered to be very reliable and extremely suitable for rescue vehicles such as ambulances.

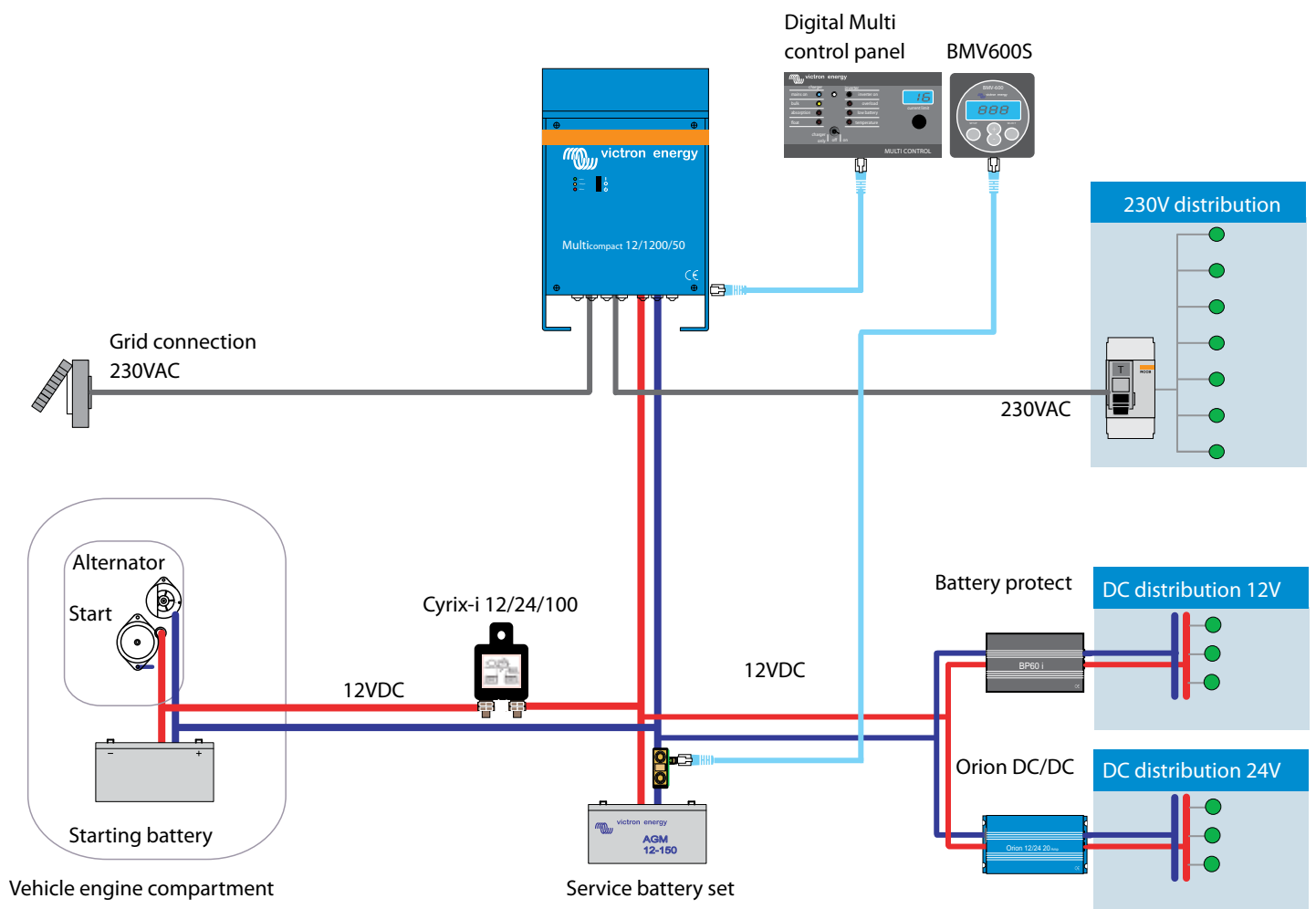

Schematic overview of the installation in the ambulances in Paris.

Electric coffee cart

The Netherlands - Espressi



Coffee cart

Dutch-based company Espressi, which rents out various types of mobile espresso machines, has developed a coffee cart that is powered exclusively by electricity. The coffee cart can be driven and operated on electricity and used in any location, thanks to its on-board equipment. The electric coffee cart can be used for a diversity of events: weddings, openings, business functions, exhibitions, festivals and conferences.

Victron equipment

To ensure that the coffee cart can be operated without any need whatsoever for mains electricity, the vehicle is equipped with the following:

- 1 x Quattro 48V 10kVA
- 1 x Battery Monitor BMV 600
- 48V 1000A OPzV batteries



Devices

The following devices are powered by the electricity stored in the batteries:

- Coffee machine
- Refrigeration system
- Sun screen
- Coffee grinder
- Lighting
- The vehicle's drive system

The coffee cart has a special switch to operate the electrical devices and the vehicle's drive system separately and so avoid using too much electricity at the same time.

Consumption

When the batteries are fully charged, the coffee cart can make coffee for up to 5 hours. That equates to around 1000 cups of coffee. When all devices are running simultaneously the total power consumption is 8kW.

When the coffee machine is not being used, the coffee cart has a range of 300 kilometres.

The Battery Monitor checks on how full the batteries are so that the coffee cart is always able to get back home.

Go to www.espressi.nl to find out more about Espresso's coffee carts.

1. Simple system with only DC consumers

The battery charger charges the battery and functions as a power supply for the consumers.

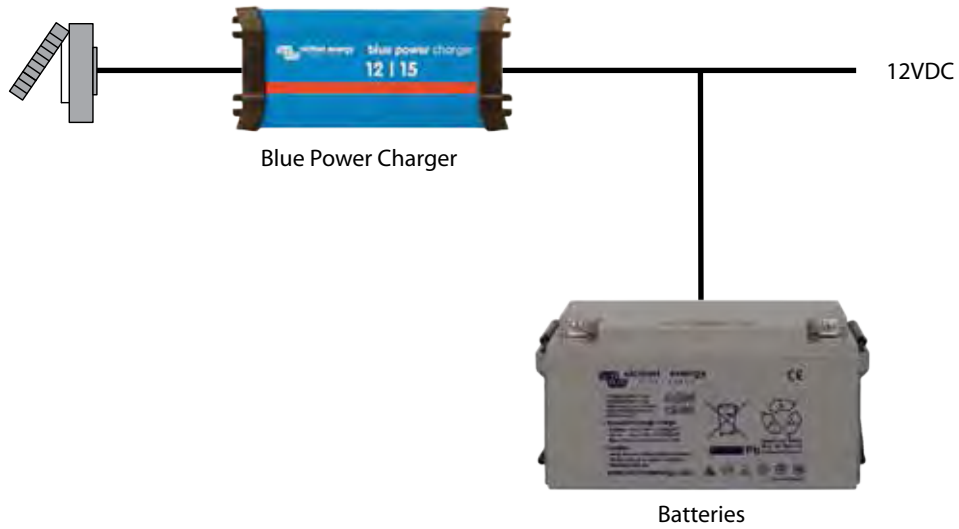

2. Charger system with inverter

This system contains a charger with three isolated outputs in order to charge three isolated battery banks. The inverter in this system provides 230VAC loads.

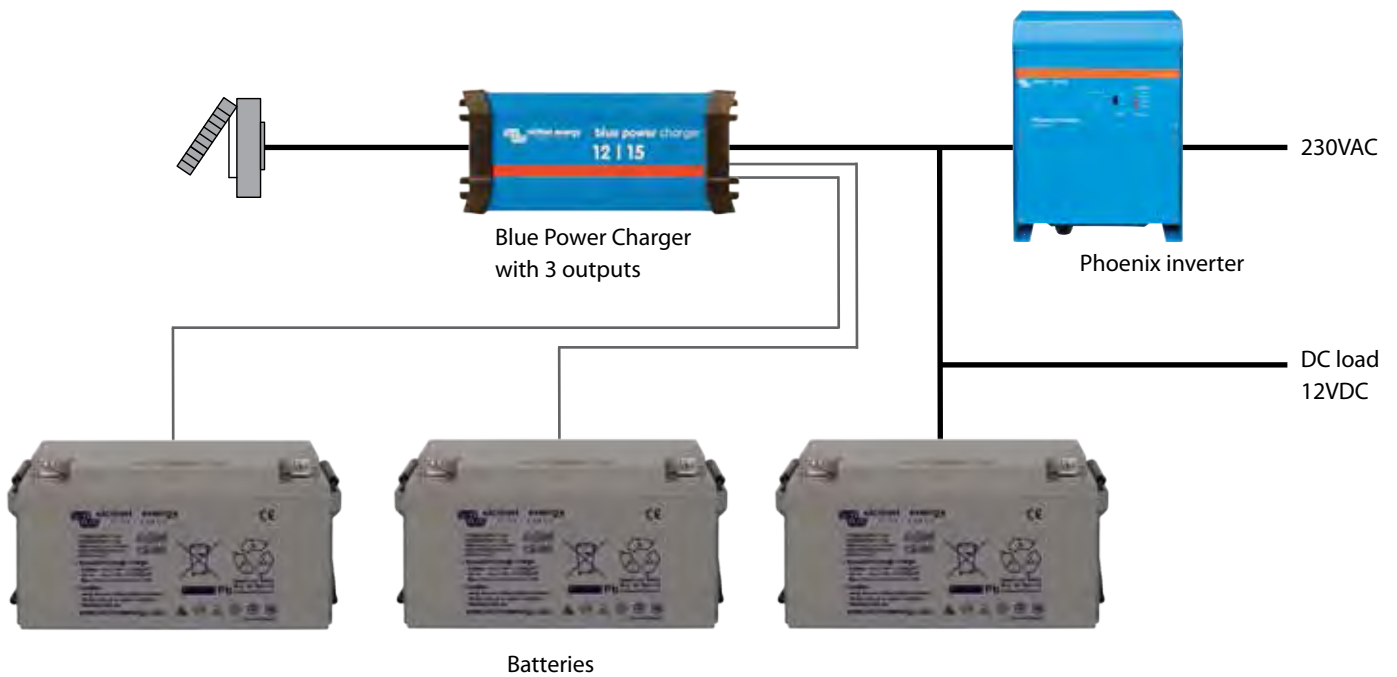

3. Multi system

The MultiPlus combines the charger and inverter functionality. This will result in easy installation and features like Power-Control and PowerAssist.

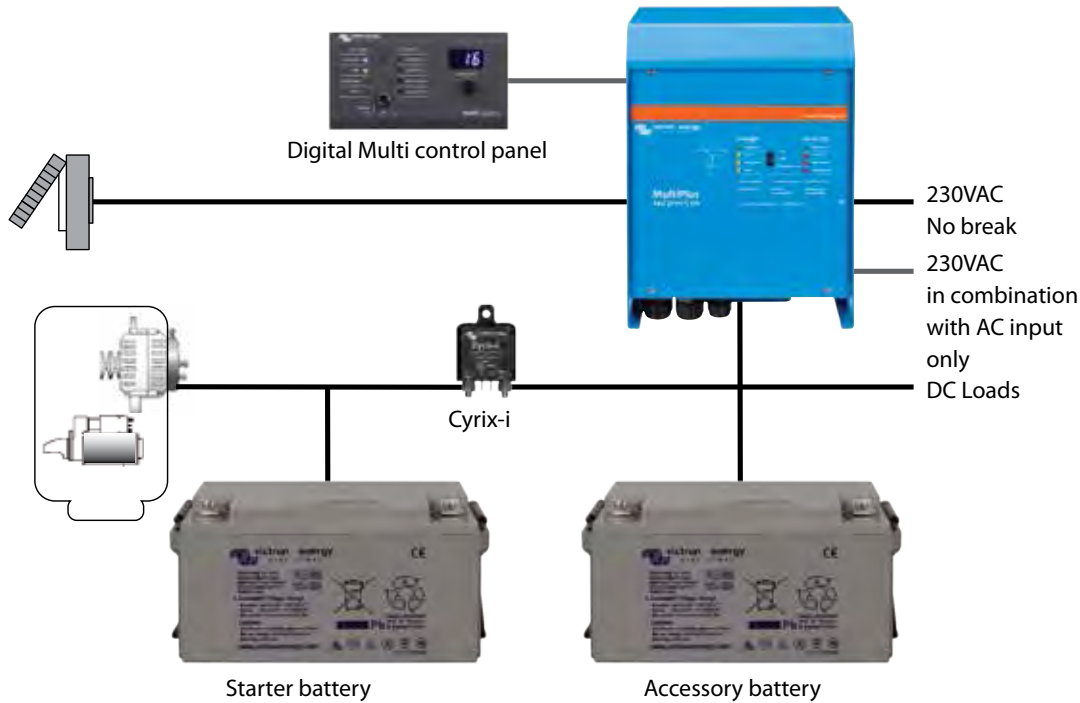

MultiPlus vs Quattro

The MultiPlus and Quattro products play a central role in both AC and DC systems. They are both powerful battery chargers and inverters in one box.

The amount of available AC sources is the deciding factor when choosing between the Quattro and the Multi.

The big difference is that a Quattro can take two AC sources, and switch between them based on intelligent rules. It has a built-in transfer-switch. The MultiPlus can take only one AC source.

4. Quattro system

The Quattro has the same functions as the MultiPlus, but with an extra addition: a transfer system which automatically selects the available input.

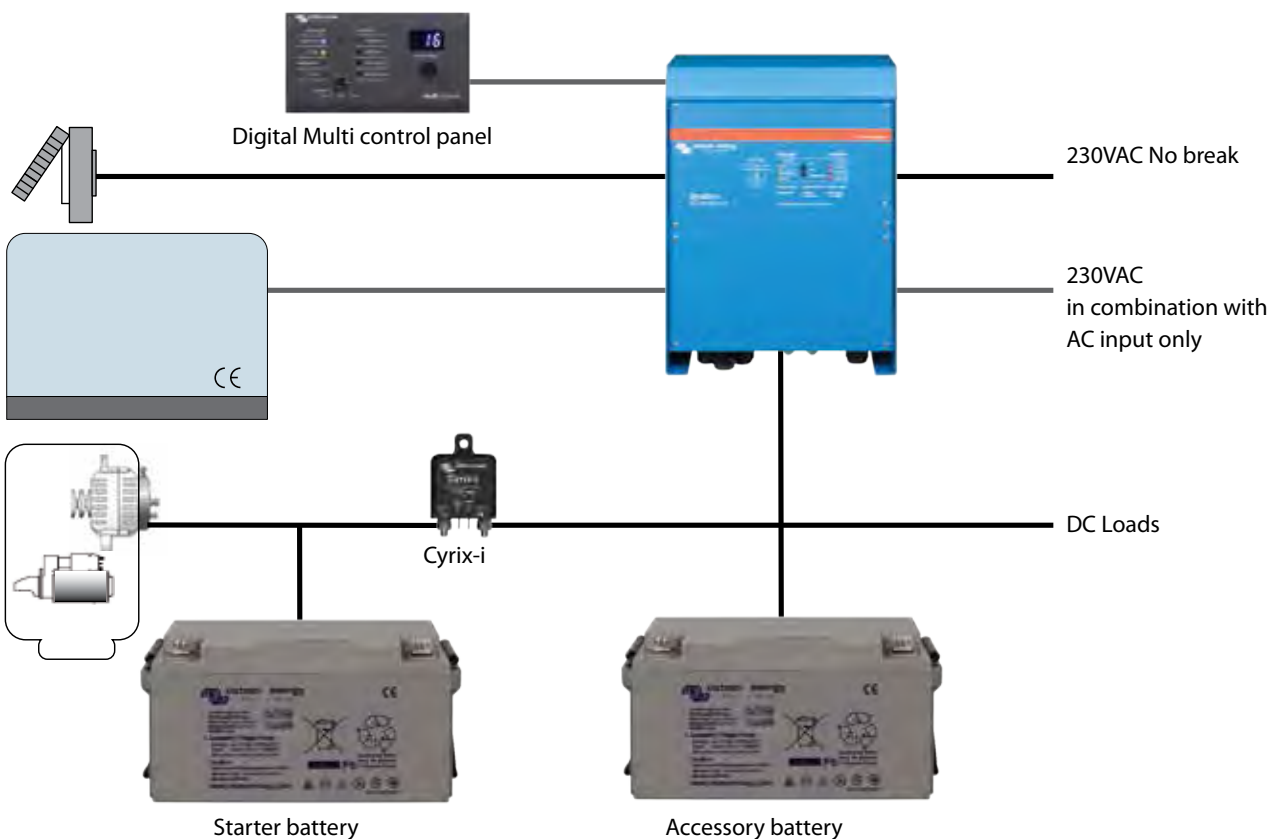

5. Parallel system

Our inverters, Multis and Quattros can be paralleled to meet higher power requirements. A simple setting with our VEConfigure configuration software is sufficient.

Easy to configure

Configuring parallel and three-phase systems is easy. Our VEConfigure software tool allows the installer to put components together, without any hardware changes or dipswitches. Just using standard products.

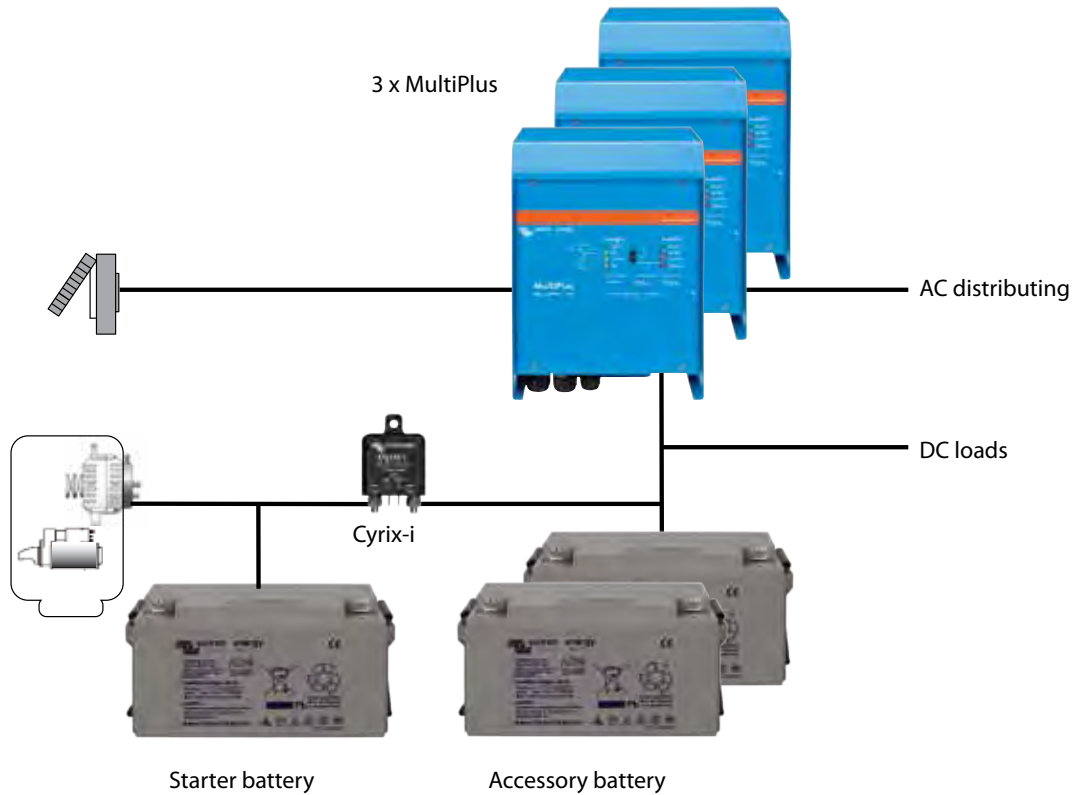

6. Three-phase system

Similar to connecting units in parallel they can also be connected in split-phase and three-phase configurations.

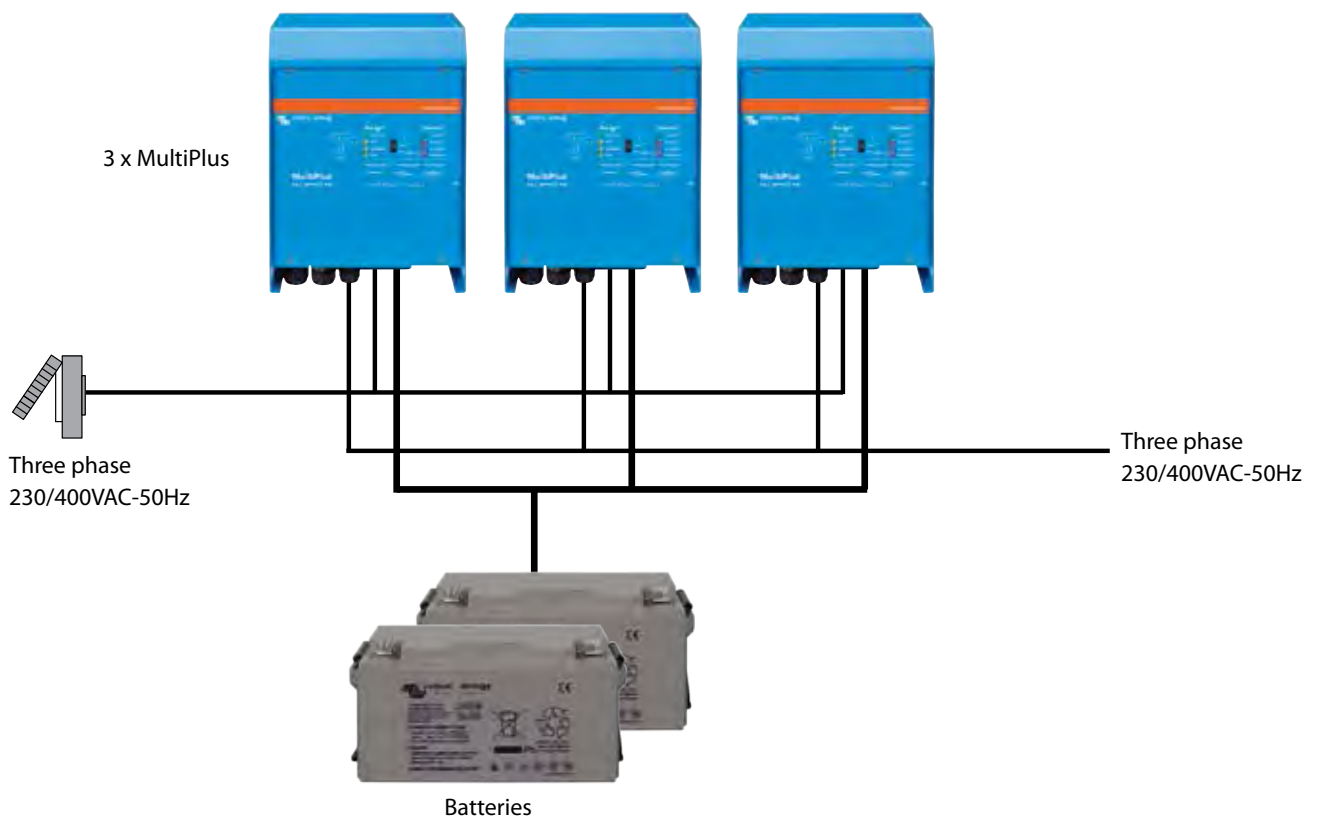

7. Multplus system with DC generator

In this configuration the batteries are being charged directly with the DC generator, the alternator or AC power.

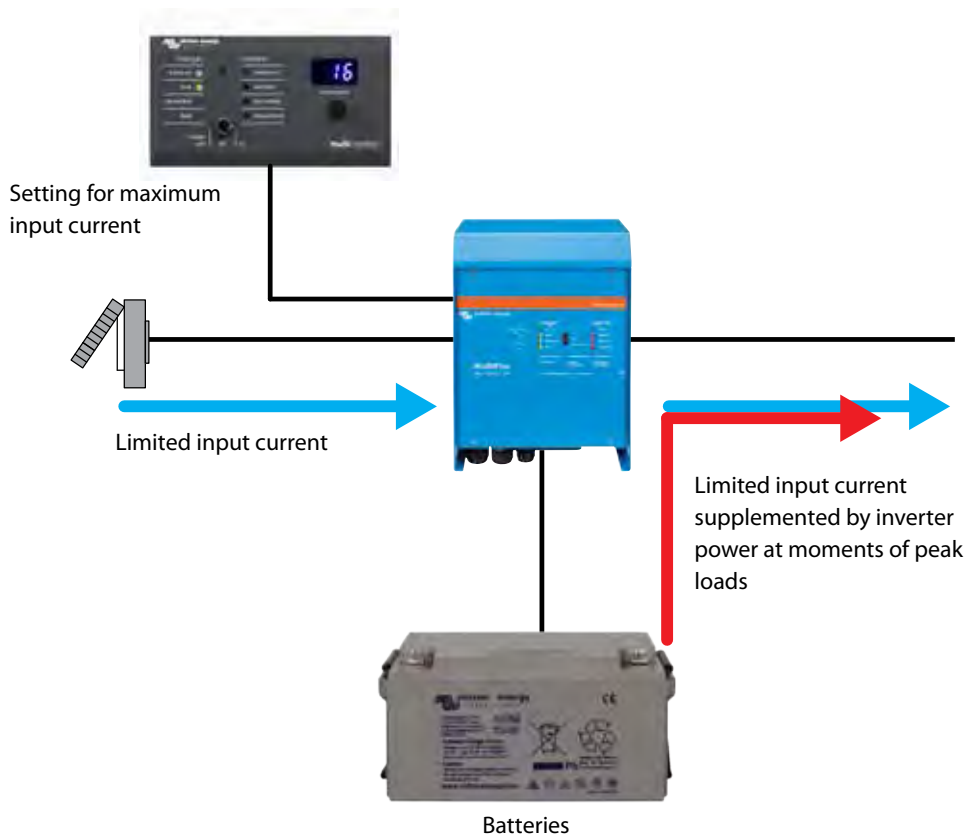
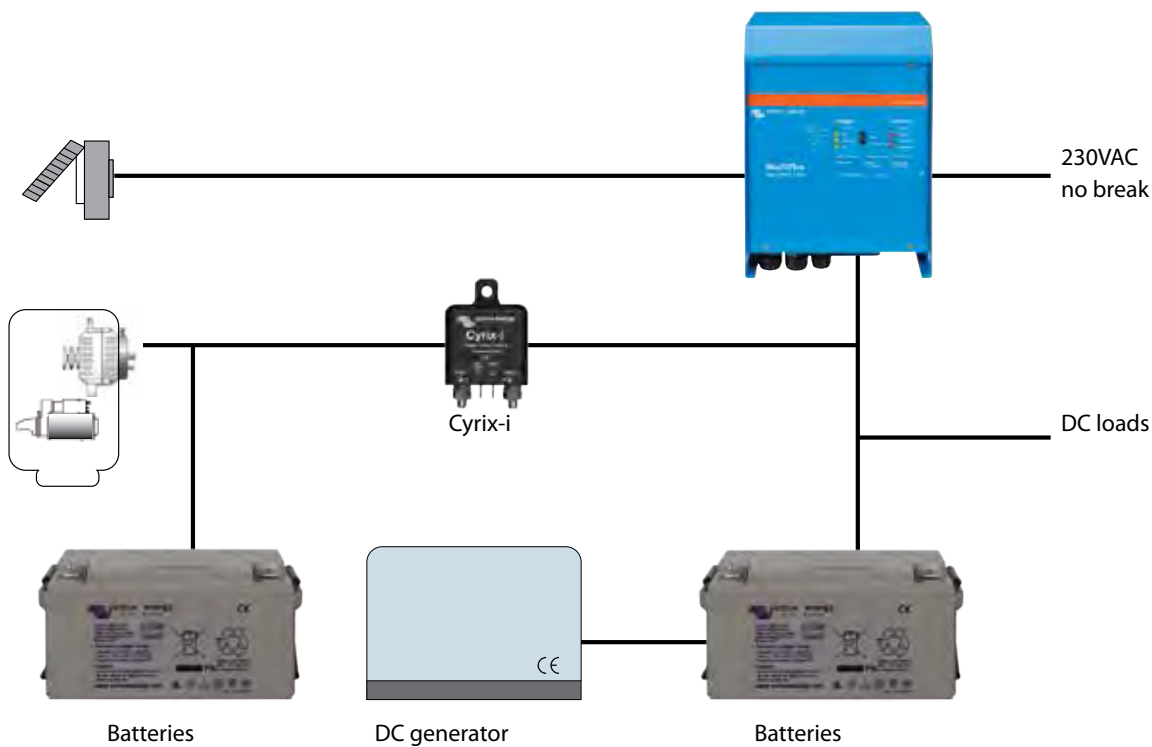

PowerAssist – boosting the capacity of AC or generator power

This unique Victron feature allows the MultiPlus to supplement the capacity of the mains or generator power. Where peak power is so often required only for a limited period, the MultiPlus will make sure that insufficient mains or generator power is immediately compensated with power from the battery. When the load reduces, the spare power is used to recharge the battery bank.

It is therefore no longer necessary to size a generator on the maximum peak load. Use the most efficient size generator instead.

Note: this feature is available in both the MultiPlus and the Quattro.

Our systems are comprised of various components. Some of which are specifically designed for specific markets. Other Victron components are applicable for a wide range of applications. You are able to find the specifications and other detailed information about these components in the 'Technical Information' section.



Battery Monitor

Key tasks of the Victron Battery Monitor are measuring charge and discharge currents as well as calculating the state-of-charge and time-to-go of a battery. An alarm is sent when certain limits are exceeded (such as an excessive discharge). It is also possible for the battery monitor to exchange data with the Victron Global Remote. This includes sending alarms.



Color Control GX

The Color Control GX provides intuitive control and monitoring for all products connected to it. The list of Victron products that can be connected is endless: Inverters, Multi's, Quattro's, MPPT 150/70, BMV-600 series, BMV-700 series, Skylla-i, Lynx Ion and even more.



VRM Online Portal

Besides monitoring and controlling products on the Color Control GX, the information is also forwarded to our free remote monitoring website: the VRM Online Portal. To get an impression of the VRM Online Portal, visit <https://vrm.victronenergy.com> and use the 'Take a look inside' button. The portal is free of charge.



Digital Multi Control Panel GX

With this panel you are able to remotely monitor and control Multiplus and Quattro systems. A simple turn of the button can limit the power supply of for example a generator and/or shore-side current. The setting range is up to 200A.



Filax 2: the ultra fast transfer switch

The Filax has been designed to switch sensitive loads, such as computers or modern entertainment equipment from one AC source to another. The priority source typically is the mains, a generator or shore power. The alternate source typically is an inverter.

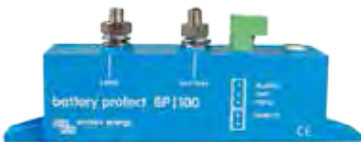

BatteryProtect Models 12/24V: 65A, 100A & 220A Model 48V: 100A

The BatteryProtect disconnects the battery from non-essential loads before it is completely discharged (which would damage the battery) or before it has insufficient power left to crank the engine.



Shore power cable

- Waterproof Shore Power Cable and Inlet IP67
- Moulded Plug and Connector
- Power indication LED
- Protection Cap
- Stainless Steel Inlet

**Note - for our newest datasheets please refer to our website:
www.victronenergy.com**

TECHNICAL INFORMATION

Phoenix Inverters 180VA - 1200VA 120V and 230V	24
Phoenix Inverters 1200VA - 5000VA 230V	26
MultiPlus inverter/charger 800VA - 5kVA 230V	28
Quattro inverter/charger 3kVA - 15kVA 230V	30
Blue Power Battery Charger GX IP20	34
Blue Power Battery Charger GX IP20 12-25 and 24-12	35
Blue Power Battery Charger IP22	36
Blue power charger IP65	38
Blue Power Battery Charger IP67	39
Blue Smart IP65 Charger	41
Blue Power Battery Charger waterproof IP65 180 - 265VAC	45
Centaur charger 12/24V	48
Phoenix battery charger 12/24V	50
Skylla-i battery charger 24V	52
Skylla TG charger 24/48V 230V	54
Orion DC/DC converters	56
Orion IP67 24/12 DC-DC converter	58
Blue Power Panel	59
Color Control GX	60
Cyrix-ct 12/24 V 120 A and 230 A	64
Cyrix-i 400A 12/24V and 24/48V	66
Victron Global Remote 2 and Victron Ethernet Remote	68
BMV 700 series: precision battery monitoring	70
Argo diode battery isolators	72
Argo FET battery isolators	73
Battery Balancer	74
GEL and AGM batteries	76
12,8V lithium iron phosphate batteries	80
Telecom batteries	82
BlueSolar monocrystalline panels	83
BlueSolar polycrystalline panels	85
BlueSolar charge controllers - overview	86
BlueSolar charge controller MPPT 75/10, 75/15 & MPPT 100/15	87
MultiPlus principle	88





Phoenix Inverter 12/180

SinusMax – Superior engineering

Developed for professional duty, the Phoenix range of inverters is suitable for the widest range of applications. The design criteria have been to produce a true sine wave inverter with optimized efficiency but without compromise in performance. Employing hybrid HF technology, the result is a top quality product with compact dimensions, light in weight and capable of supplying power, problem-free, to any load.

Extra start-up power

A unique feature of the SinusMax technology is very high start-up power. Conventional high frequency technology does not offer such extreme performance. Phoenix Inverters, however, are well suited to power up difficult loads such as computers and low power electric tools.

To transfer the load to another AC source: the automatic transfer switch

For our lower power models we recommend the use of our Filax Automatic Transfer Switch. The Filax features a very short switchover time (less than 20 milliseconds) so that computers and other electronic equipment will continue to operate without disruption.



Phoenix Inverter 12/800 with Schuko socket

LED diagnosis

Please see manual for a description.

Remote on/off switch

Connector for remote on/off switch available on all models.

DIP switch for 50/60Hz selection (48/350 model only)

Available with different output sockets

Please see pictures below.



Phoenix Inverter 12/350 with IEC-320 sockets



Phoenix Inverter 12/180 with Schuko socket



Phoenix Inverter 12/180 with Nema 5-15R sockets



Phoenix Inverter 12/800 with IEC-320 socket



Phoenix Inverter 12/800 with Schuko socket



Phoenix Inverter 12/800 with BS 1363 socket



Phoenix Inverter 12/800 with AN/NZS 3112 socket



Phoenix Inverter 12/800 with Nema 5-15R socket

Phoenix Inverter	12 Volt 24 Volt 48 Volt	12/180 24/180	12/350 24/350 48/350	12/800 24/800 48/800	12/1200 24/1200 48/1200
Cont. AC power at 25°C (VA) (3)		180	350	800	1200
Cont. power at 25°C / 40°C (W)		175 / 150	300 / 250	700 / 650	1000 / 900
Peak power (W)		350	700	1600	2400
Output AC voltage / frequency (4)		110 VAC or 230 VAC +/- 3% 50 Hz or 60 Hz +/- 0,1%			
Input voltage range (V DC)		10,5 - 15,5 / 21,0 - 31,0 / 42,0 - 62,0		9,2 - 17,3 / 18,4 - 34,0 / 36,8 - 68,0	
Low battery alarm (V DC)		11,0 / 22 / 44		10,9 / 21,8 / 43,6	
Low battery shut down (V DC)		10,5 / 21 / 42		9,2 / 18,4 / 36,8	
Low battery auto recovery (V DC)		12,5 / 25 / 50		12,5 / 25 / 50	
Max. efficiency (%)		87 / 88	89 / 89 / 90	91 / 93 / 94	92 / 94 / 94
Zero load power (W)		2,6 / 3,8	3,1 / 5,0 / 6,0	6 / 5 / 4	6 / 5 / 6
Zero load power in search mode		n. a.	n. a.	2	2
Protection (2)		a - e			
Operating temperature range		-40 to +50°C (fan assisted cooling)			
Humidity (non-condensing)		max 95%			
ENCLOSURE					
Material & Colour		aluminium (blue Ral 5012)			
Battery-connection		1)	1)	1)	1)
Standard AC outlets		230V: IEC-320 (IEC-320 plug included), CEE 7/4 (Schuko) 120V: Nema 5-15R			
Other outlets (at request)		BS 1363 (United Kingdom) AN/NZS 3112 (Australia, New Zealand)			
Protection category		IP 20			
Weight (kg / lbs)		2,7 / 5,4	3,5 / 7,7	6,5 / 14,3	8,5 / 18,7
Dimensions (hxwx in mm) (hxwx in inches)		72x132x200 2.8x5.2x7.9	72x155x237 2.8x6.1x9.3	104 x 194 x 305 4.1 x 7.6 x 12.0	104 x 194 x 305 4.1 x 7.6 x 12.0
ACCESSORIES					
Remote on-off switch		Two pole connector			
Automatic transfer switch		Filax			
STANDARDS					
Safety		EN 60335-1			
Emission Immunity		EN 55014-1 / EN 55014-2/ EN 61000-6-2 / EN 61000-6-3			
1) Battery cables of 1.5 meter (12/180 with cigarette plug)		3) Non-linear load, crest factor 3:1			
2) Protection key: a) output short circuit b) overload c) battery voltage too high d) battery voltage too low e) temperature too high		4) Frequency can be set by DIP switch (48/350 model only)			



Battery Alarm

An excessively high or low battery voltage is indicated by an audible and visual alarm, and a relay for remote signalling.



BMV-700 Battery Monitor

The BMV-700 Battery Monitor features an advanced microprocessor control system combined with high resolution measuring systems for battery voltage and charge/discharge current. Besides this, the software includes complex calculation algorithms to exactly determine the state of charge of the battery. The BMV-700 selectively displays battery voltage, current, consumed Ah or time to go. The monitor also stores a host of data regarding performance and use of the battery.



**Phoenix Inverter
24/5000**

SinusMax - Superior engineering

Developed for professional duty, the Phoenix range of inverters is suitable for the widest range of applications. The design criteria have been to produce a true sine wave inverter with optimized efficiency but without compromise in performance. Employing hybrid HF technology, the result is a top quality product with compact dimensions, light in weight and capable of supplying power, problem-free, to any load.

Extra start-up power

A unique feature of the SinusMax technology is very high start-up power. Conventional high frequency technology does not offer such extreme performance. Phoenix Inverters, however, are well suited to power up difficult loads such as refrigeration compressors, electric motors and similar appliances.

Virtually unlimited power thanks to parallel and 3-phase operation capability

Up to 6 units inverters can operate in parallel to achieve higher power output. Six 24/5000 units, for example, will provide 24kW / 30kVA output power. Operation in 3-phase configuration is also possible.

To transfer the load to another AC source: the automatic transfer switch

If an automatic transfer switch is required we recommend using the MultiPlus inverter/charger instead. The switch is included in these products and the charger function of the MultiPlus can be disabled. Computers and other electronic equipment will continue to operate without disruption because the MultiPlus features a very short switchover time (less than 20 milliseconds).

Computer interface

All models have a RS-485 port. All you need to connect to your PC is our MK2 interface (see under accessories). This interface takes care of galvanic isolation between the inverter and the computer, and converts from RS-485 to RS-232. A RS-232 to USB conversion cable is also available. Together with our VECconfigure software, which can be downloaded free of charge from our website, all parameters of the inverters can be customized. This includes output voltage and frequency, over and under voltage settings and programming the relay. This relay can for example be used to signal several alarm conditions, or to start a generator. The inverters can also be connected to VENet, the new power control network of Victron Energy, or to other computerized monitoring and control systems.

New applications of high power inverters

The possibilities of paralleled high power inverters are truly amazing. For ideas, examples and battery capacity calculations please refer to our book 'Energy Unlimited' (available free of charge from Victron Energy and downloadable from www.victronenergy.com).



**Phoenix Inverter Compact
24/1600**

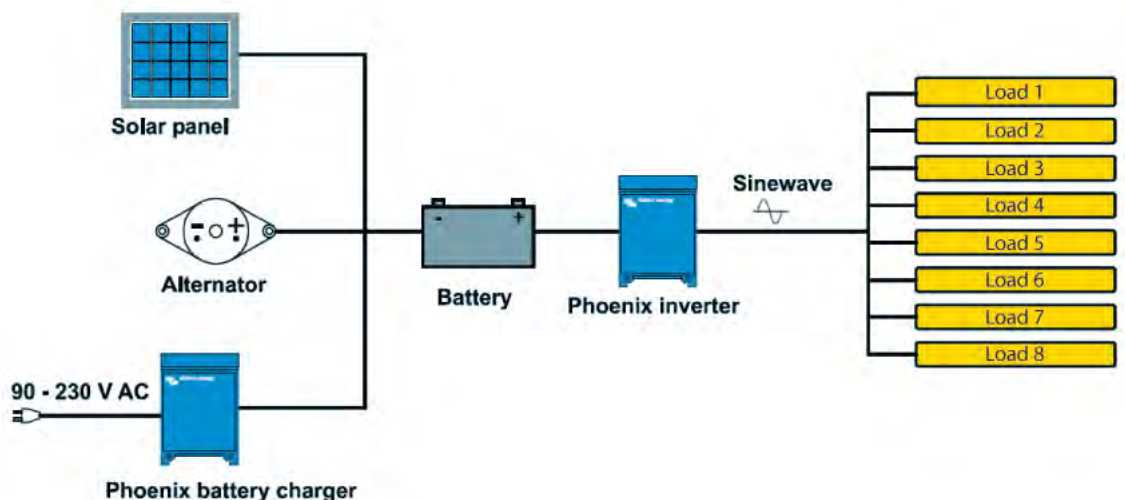

Phoenix Inverter	C12/1200 C24/1200 C48/1200	C12/1600 C24/1600 C48/1600	C12/2000 C24/2000	12/3000 24/3000 48/3000	24/5000 48/5000
Parallel and 3-phase operation	Yes				
INVERTER					
Input voltage range (V DC)	9,5 – 17V 19 – 33V 38 – 66V				
Output	Output voltage: 230 VAC ±2% Frequency: 50 Hz ± 0,1% (1)				
Cont. output power at 25°C (VA) (2)	1200	1600	2000	3000	5000
Cont. output power at 25°C (W)	1000	1300	1600	2400	4000
Cont. output power at 40°C (W)	900	1200	1450	2200	3700
Cont. output power at 65°C (W)	600	800	1000	1700	3000
Peak power (W)	2400	3000	4000	6000	10000
Max. efficiency 12/ 24 /48 V (%)	92 / 94 / 94	92 / 94 / 94	92 / 92	93 / 94 / 95	94 / 95
Zero load power 12 / 24 / 48 V (W)	8 / 10 / 12	8 / 10 / 12	9 / 11	20 / 20 / 25	30 / 35
Zero load power in AES mode (W)	5 / 8 / 10	5 / 8 / 10	7 / 9	15 / 15 / 20	25 / 30
Zero load power in Search mode (W)	2 / 3 / 4	2 / 3 / 4	3 / 4	8 / 10 / 12	10 / 15
GENERAL					
Programmable relay (3)	Yes				
Protection (4)	a - g				
VE.Bus communication port	For parallel and three phase operation, remote monitoring and system integration				
Remote on-off	Yes				
Common Characteristics	Operating temperature range: -40 to +65°C (fan assisted cooling) Humidity (non-condensing): max 95%				
ENCLOSURE					
Common Characteristics	Material & Colour: aluminium (blue RAL 5012) Protection category: IP 21				
Battery-connection	battery cables of 1.5 meter included		M8 bolts	2+2 M8 bolts	
230 V AC-connection	G-ST18i plug		Spring-clamp	Screw terminals	
Weight (kg)	10		12	18	30
Dimensions (hxwhd in mm)	375x214x110		520x255x125	362x258x218	444x328x240
STANDARDS					
Safety	EN 60335-1				
Emission Immunity	EN 55014-1 / EN 55014-2				
1) Can be adjusted to 60 Hz and to 240 V 2) Non-linear load, crest factor 3:1 3) Programmable relay that can a.o. be set for general alarm, DC under voltage or genset start/stop function. AC rating: 230 V / 4 A DC rating: 4 A up to 35 VDC, 1A up to 60VDC	4) Protection key: a) output short circuit b) overload c) battery voltage too high d) battery voltage too low e) temperature too high f) 230 V AC on inverter output g) input voltage ripple too high				



Phoenix Inverter Control

This panel can also be used on a MultiPlus Inverter/Charger when an automatic transfer switch but no charger function is desired. The brightness of the LEDs is automatically reduced during night time.



Computer controlled operation and monitoring

Several interfaces are available:

- **MK2.2 VE.Bus to RS232 converter**
Connects to the RS232 port of a computer (see 'A guide to VEConfigure')
- **MK2-USB VE.Bus to USB converter**
Connects to a USB port (see 'A guide to VEConfigure')
- **VE.Net to VE.Bus converter**
Interface to VE.Net (see VE.Net documentation)
- **VE.Bus to NMEA 2000 converter**
- **Victron Global Remote**
The Global Remote is a modem which sends alarms, warnings and system status reports to cellular phones via text messages (SMS). It can also log data from Victron Battery Monitors, Multis, Quattros and Inverters to a website through a GPRS connection. Access to this website is free of charge.
- **Victron Ethernet Remote**
To connect to Ethernet.
- **Color Control panel**
Behind the color LCD a Linux microcomputer runs open source software. The Color Control (CCGX) provides intuitive control and monitoring for all products connected to it. The list of Victron products that can be connected is endless: Inverters, Multis, Quattros, all our latest MPPT solar chargers, BMV-700, BMV-600, Lynx Ion + Shunt and more. The information can also be forwarded to our free remote monitoring website: the VRM Online Portal.



BMV-700 Battery Monitor

The BMV-700 Battery Monitor features an advanced microprocessor control system combined with high resolution measuring systems for battery voltage and charge/discharge current. Besides this, the software includes complex calculation algorithms, like Peukert's formula, to exactly determine the state of charge of the battery. The BMV-700 selectively displays battery voltage, current, consumed Ah or time to go. The monitor also stores a host of data regarding performance and use of the battery.

Several models available (see battery monitor documentation).

MultiPlus
24/3000/70

Two AC Outputs

The main output has no break functionality. The MultiPlus takes over the supply to the connected loads in the event of a grid failure or when shore/generator power is disconnected. This happens so fast (less than 20 milliseconds) that computers and other electronic equipment will continue to operate without disruption. The second output is live only when AC is available on one of the inputs of the MultiPlus. Loads that should not discharge the battery, like a water heater for example can be connected to this output (second output available on models rated at 3 kVA and more).

Virtually unlimited power thanks to parallel operation

Up to 6 Multis can operate in parallel to achieve higher power output. Six 24/5000/120 units, for example, will provide 25 kW / 30 kVA output power with 720 Amps charging capacity.

Three phase capability

In addition to parallel connection, three units of the same model can be configured for three phase output. But that's not all: up to 6 sets of three units can be parallel connected for a huge 75 kW / 90 kVA inverter and more than 2000 Amps charging capacity.

PowerControl - Dealing with limited generator, shore side or grid power

The MultiPlus is a very powerful battery charger. It will therefore draw a lot of current from the generator or shore side supply (nearly 10 A per 5 kVA Multi at 230 VAC). With the Multi Control Panel a maximum generator or shore current can be set. The MultiPlus will then take account of other AC loads and use whatever is extra for charging, thus preventing the generator or shore supply from being overloaded.

PowerAssist - Boosting the capacity of shore or generator power

This feature takes the principle of PowerControl to a further dimension. It allows the MultiPlus to supplement the capacity of the alternative source. Where peak power is so often required only for a limited period, the MultiPlus will make sure that insufficient shore or generator power is immediately compensated for by power from the battery. When the load reduces, the spare power is used to recharge the battery.

Solar energy: AC power available even during a grid failure

The Quattro can be used in off grid as well as grid connected PV and other alternative energy systems. Loss of mains detection software is available.

System configuring

- In case of a stand-alone application, if settings have to be changed, this can be done in a matter of minutes with a DIP switch setting procedure.
- Parallel and three phase applications can be configured with VE.Bus Quick Configure and VE.Bus System Configurator software.
- Off grid, grid interactive and self-consumption applications, involving grid-tie inverters and/or MPPT Solar Chargers can be configured with Assistants (dedicated software for specific applications).

On-site Monitoring and control

Several options are available: Battery Monitor, Multi Control Panel, Ve.Net Blue Power Panel, Color Control Panel, smartphone or tablet (Bluetooth Smart), laptop or computer (USB or RS232).

Remote Monitoring and control

Victron Ethernet Remote, Victron Global Remote and the Color Control Panel.

Data can be stored and displayed on our VRM (Victron Remote Management) website, free of charge.

Remote configuring

When connected to the Ethernet, systems with a Color Control panel can be accessed and settings can be changed.

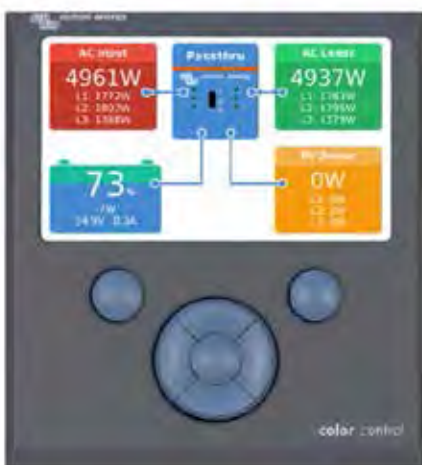
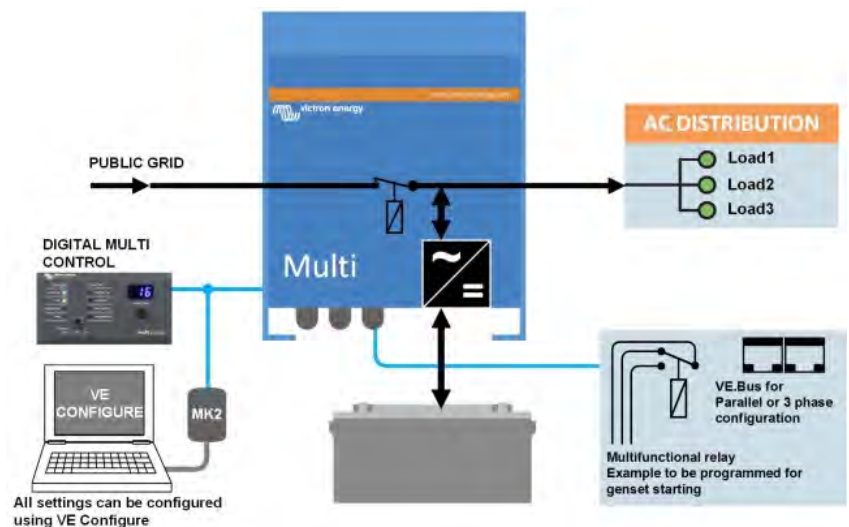
MultiPlus Compact
12/2000/80

Color Control Panel, showing a PV application

MultiPlus	12 Volt 24 Volt 48 Volt	C 12/800/35 C 24/ 800/16	C 12/1200/50 C 24/1200/25	C 12/1600/70 C 24/1600/40	C 12/2000/80 C 24/2000/50	12/3000/120 24/3000/70 48/3000/35	24/5000/120 48/5000/70
PowerControl		Yes	Yes	Yes	Yes	Yes	Yes
PowerAssist		Yes	Yes	Yes	Yes	Yes	Yes
Transfer switch (A)		16	16	16	30	16 or 50	100
INVERTER							
Input voltage range (V DC)		9,5 – 17 V		19 – 33 V	38 – 66 V		
Output		Output voltage: 230 VAC ± 2%			Frequency: 50 Hz ± 0,1% (1)		
Cont. output power at 25°C (VA) (3)	800	1200	1600	2000	3000	5000	
Cont. output power at 25°C (W)	700	1000	1300	1600	2400	4000	
Cont. output power at 40°C (W)	650	900	1200	1400	2200	3700	
Cont. output power at 65°C (W)	400	600	800	1000	1700	3000	
Peak power (W)	1600	2400	3000	4000	6000	10.000	
Maximum efficiency (%)	92 / 94	93 / 94	93 / 94	93 / 94	93 / 94	93 / 94 / 95	94 / 95
Zero load power (W)	8 / 10	8 / 10	8 / 10	9 / 11	20 / 20 / 25	30 / 35	
Zero load power in AES mode (W)	5 / 8	5 / 8	5 / 8	7 / 9	15 / 15 / 20	25 / 30	
Zero load power in Search mode (W)	2 / 3	2 / 3	2 / 3	3 / 4	8 / 10 / 12	10 / 15	
CHARGER							
AC Input		Input voltage range: 187-265 VAC		Input frequency: 45 – 65 Hz	Power factor: 1		
Charge voltage 'absorption' (V DC)		14,4 / 28,8 / 57,6					
Charge voltage 'float' (V DC)		13,8 / 27,6 / 55,2					
Storage mode (V DC)		13,2 / 26,4 / 52,8					
Charge current house battery (A) (4)	35 / 16	50 / 25	70 / 40	80 / 50	120 / 70 / 35	120 / 70	
Charge current starter battery (A)		4 (12 V and 24 V models only)					
Battery temperature sensor		yes					
GENERAL							
Auxiliary output (5)	n. a.	n. a.	n. a.	n. a.	Yes (16A)	Yes (25A)	
Programmable relay (6)		Yes					
Protection (2)		a - g					
VE.Bus communication port		For parallel and three phase operation, remote monitoring and system integration					
General purpose com. port	n. a.	n. a.	n. a.	n. a.	Yes	Yes	
Remote on-off		Yes					
Common Characteristics		Operating temp. range: -40 to +65°C (fan assisted cooling) Humidity (non-condensing): max 95%					
ENCLOSURE							
Common Characteristics		Material & Colour: aluminium (blue RAL 5012)			Protection category: IP 21		
Battery-connection		battery cables of 1,5 meter		M8 bolts	Four M8 bolts (2 plus and 2 minus connections)		
230 V AC-connection		G-ST18i connector		Spring-clamp	Screw terminals 13 mm ² (6 AWG)		
Weight (kg)	10	10	10	12	18	30	
Dimensions (hwxwd in mm)		375x214x110		520x255x125	362x258x218	444x328x240	
STANDARDS							
Safety		EN-IEC 60335-1, EN-IEC 60335-2-29, IEC 62109-1					
Emission, Immunity		EN 55014-1, EN 55014-2, EN 61000-3-3, EN 61000-6-3, EN 61000-6-2, EN 61000-6-1					
Automotive Directive		2004/104/EC					
Anti-islanding		See our website					

1) Can be adjusted to 60 HZ; 120 V 60 Hz on request
 2) Protection key:
 a) output short circuit
 b) overload
 c) battery voltage too high
 d) battery voltage too low
 e) temperature too high
 f) 230 VAC on inverter output
 g) input voltage ripple too high

3) Non-linear load, crest factor 3:1
 4) At 25°C ambient
 5) Switches off when no external AC source available
 6) Programmable relay that can a.o. be set for general alarm, DC under voltage or genset start/stop function
 AC rating: 230 V/4A
 DC rating: 4 A up to 35 VDC, 1 A up to 60 VDC



Digital Multi Control Panel
 A convenient and low cost solution for remote monitoring, with a rotary knob to set PowerControl and PowerAssist levels.



Blue Power Panel
 Connects to a Multi or Quattro and all VE.Net devices, in particular the VE.Net Battery Controller.
 Graphic display of currents and voltages.



Computer controlled operation and monitoring
 Several interfaces are available:
 - **MK2.2 VE.Bus to RS232 converter**
 Connects to the RS232 port of a computer (see 'A guide to VEConfigure')
 - **MK2-USB VE.Bus to USB converter**
 Connects to a USB port (see 'A guide to VEConfigure')
 - **VE.Net to VE.Bus converter**
 Interface to VE.Net (see VE.Net documentation)
 - **VE.Bus to NMEA 2000 converter**
 - **Victron Global Remote**
 The Global Remote is a modem which sends alarms, warnings and system status reports to cellular phones via text messages (SMS). It can also log data from Victron Battery Monitors, Multis, Quattros and Inverters to a website through a GPRS connection. Access to this website is free of charge.
 - **Victron Ethernet Remote**
 To connect to the Ethernet.
 - **Color Control panel (see picture on page 1)**
 Behind the color LCD a Linux microcomputer runs open source software. The Color Control (CCGX) provides intuitive control and monitoring for all products connected to it. The list of Victron products that can be connected is endless: Inverters, Multis, Quattros, all our latest MPPT Solar Chargers, BMV-700, BMV-600, Lynx Ion + Shunt and more. The information can also be forwarded to our free remote monitoring website: the VRM Online Portal.



BMV-700 Battery Monitor
 The BMV-700 Battery Monitor features an advanced microprocessor control system combined with high resolution measuring systems for battery voltage and charge/discharge current. Besides this, the software includes complex calculation algorithms, like Peukert's formula, to exactly determine the state of charge of the battery. The BMV-700 selectively displays battery voltage, current, consumed Ah or time to go. The monitor also stores a host of data regarding performance and use of the battery.
 Several models available (see battery monitor documentation).

Quattro inverter/charger 3kVA - 15kVA 230V

Lithium Ion battery compatible



Quattro
48/5000/70-100/100



Quattro
24/3000/70-50/50

Two AC inputs with integrated transfer switch

The Quattro can be connected to two independent AC sources, for example the public grid and a generator, or two generators. The Quattro will automatically connect to the active source.

Two AC Outputs

The main output has no-break functionality. The Quattro takes over the supply to the connected loads in the event of a grid failure or when shore/generator power is disconnected. This happens so fast (less than 20 milliseconds) that computers and other electronic equipment will continue to operate without disruption. The second output is live only when AC is available on one of the inputs of the Quattro. Loads that should not discharge the battery, like a water heater for example can be connected to this output.

Virtually unlimited power thanks to parallel operation

Up to 6 Quattro units can operate in parallel. Six units 48/10000/140, for example, will provide 54 kW / 60 kVA output power and 840 Amps charging capacity.

Three phase capability

Three units can be configured for three phase output. But that's not all: up to 6 sets of three units can be parallel connected to provide 162 kW / 180 kVA inverter power and more than 2500 A charging capacity.

PowerControl – Dealing with limited generator, shoreside or grid power

The Quattro is a very powerful battery charger. It will therefore draw a lot of current from the generator or shoreside supply (16 A per 5 kVA Quattro at 230 VAC). A current limit can be set on each AC input. The Quattro will then take account of other AC loads and use whatever is spare for charging, thus preventing the generator or mains supply from being overloaded.

PowerAssist – Boosting shore or generator power

This feature takes the principle of PowerControl to a further dimension allowing the Quattro to supplement the capacity of the alternative source. Where peak power is so often required only for a limited period, the Quattro will make sure that insufficient mains or generator power is immediately compensated for by power from the battery. When the load reduces, the spare power is used to recharge the battery.

Solar energy: AC power available even during a grid failure

The Quattro can be used in off grid as well as grid connected PV and other alternative energy systems. Loss of mains detection software is available.

System configuring

- In case of a stand-alone application, if settings have to be changed, this can be done in a matter of minutes with a DIP switch setting procedure.
- Parallel and three phase applications can be configured with VE.Bus Quick Configure and VE.Bus System Configurator software.
- Off grid, grid interactive and self-consumption applications, involving grid-tie inverters and/or MPPT Solar Chargers can be configured with Assistants (dedicated software for specific applications).

On-site Monitoring and control

Several options are available: Battery Monitor, Multi Control Panel, Ve.Net Blue Power panel, Color Control panel, smartphone or tablet (Bluetooth Smart), laptop or computer (USB or RS232).

Remote Monitoring and control

Victron Ethernet Remote, Victron Global Remote and the Color Control Panel.

Data can be stored and displayed on our VRM (Victron Remote Management) website, free of charge.

Remote configuring

When connected to the Ethernet, systems with a Color Control panel can be accessed and settings can be changed.



Color Control panel, showing a PV application

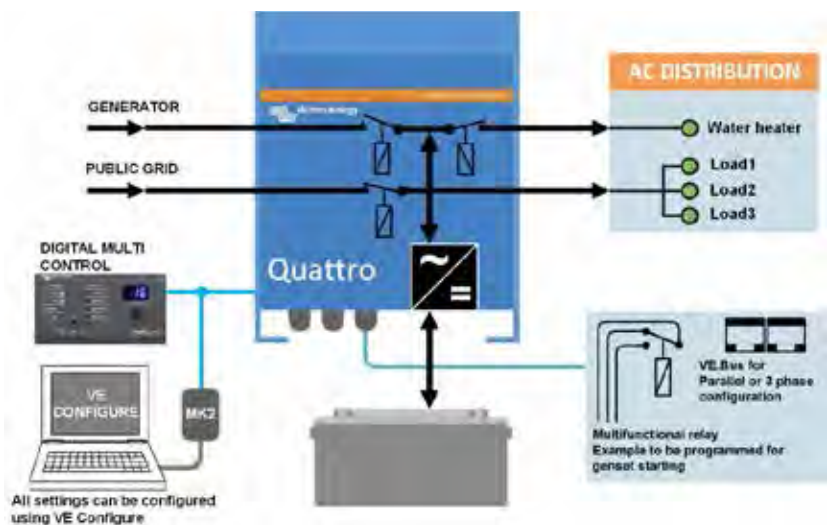

Quattro	12/3000/120-50/50 24/3000/70-50/50	12/5000/220-100/100 24/5000/120-100/100 48/5000/70-100/100	24/8000/200-100/100 48/8000/110-100/100	48/10000/140-100/100	48/15000/210-100/100
PowerControl / PowerAssist	Yes				
Integrated Transfer switch	Yes				
AC inputs (2x)	Input voltage range: 187-265 VAC Input frequency: 45 – 65 Hz Power factor: 1				
Maximum feed through current (A)	2x 50	2x100	2x100	2x100	2x100
INVERTER					
Input voltage range (V DC)	9,5 – 17V 19 – 33V 38 – 66V				
Output (1)	Output voltage: 230 VAC ± 2% Frequency: 50 Hz ± 0,1%				
Cont. output power at 25°C (VA) (3)	3000	5000	8000	10000	15000
Cont. output power at 25°C (W)	2400	4000	6500	8000	12000
Cont. output power at 40°C (W)	2200	3700	5500	6500	10000
Cont. output power at 65°C (W)	1700	3000	3600	4500	7000
Peak power (W)	6000	10000	16000	20000	25000
Maximum efficiency (%)	93 / 94	94 / 94 / 95	94 / 96	96	96
Zero load power (W)	20 / 20	30 / 30 / 35	45 / 50	55	80
Zero load power in AES mode (W)	15 / 15	20 / 25 / 30	30 / 30	35	50
Zero load power in Search mode (W)	8 / 10	10 / 10 / 15	10 / 20	20	30
CHARGER					
Charge voltage 'absorption' (V DC)	14,4 / 28,8	14,4 / 28,8 / 57,6	28,8 / 57,6	57,6	57,6
Charge voltage 'float' (V DC)	13,8 / 27,6	13,8 / 27,6 / 55,2	27,6 / 55,2	55,2	55,2
Storage mode (V DC)	13,2 / 26,4	13,2 / 26,4 / 52,8	26,4 / 52,8	52,8	52,8
Charge current house battery (A) (4)	120 / 70	220 / 120 / 70	200 / 110	140	210
Charge current starter battery (A)	4 (12V and 24V models only)				
Battery temperature sensor	Yes				
GENERAL					
Auxiliary output (A) (5)	25	50	50	50	50
Programmable relay (6)	3x	3x	3x	3x	3x
Protection (2)	a-g				
VE.Bus communication port	For parallel and three phase operation, remote monitoring and system integration				
General purpose com. port	2x	2x	2x	2x	2x
Remote on-off	Yes				
Common Characteristics	Operating temp.: -40 to +65°C Humidity (non-condensing): max. 95%				
ENCLOSURE					
Common Characteristics	Material & Colour: aluminium (blue RAL 5012) Protection category: IP 21				
Battery-connection	Four M8 bolts (2 plus and 2 minus connections)				
230 V AC-connection	Screw terminals 13 mm ² (6 AWG)	Bolts M6	Bolts M6	Bolts M6	Bolts M6
Weight (kg)	19	34 / 30 / 30	45 / 41	45	72
Dimensions (hxxwxd in mm)	362 x 258 x 218	470 x 350 x 280 444 x 328 x 240 444 x 328 x 240	470 x 350 x 280	470 x 350 x 280	570 x 480 x 330
STANDARDS					
Safety	EN-IEC 60335-1, EN-IEC 60335-2-29, EN-IEC 62109-1				
Emission, Immunity	EN 55014-1, EN 55014-2, EN-IEC 61000-3-2, EN-IEC 61000-3-3, EN-IEC 61000-6-3, EN-IEC 61000-6-2, EN-IEC 61000-6-1				
Vehicles, aftermarket	12V and 24V models: EN 50498				
Anti-islanding	See our website				
1) Can be adjusted to 60 HZ; 120 V 60 Hz on request	3) Non-linear load, crest factor 3:1				
2) Protection key:	4) At 25°C ambient				
a) output short circuit	5) Switches off when no external AC source available				
b) overload	6) Programmable relay that can a.o. be set for general alarm, DC under voltage or genset start/stop function				
c) battery voltage too high	AC rating: 230 V / 4 A				
d) battery voltage too low	DC rating: 4 A up to 35 VDC, 1 A up to 60 VDC				
e) temperature too high					
f) 230 VAC on inverter output					
g) input voltage ripple too high					



Digital Multi Control Panel

A convenient and low cost solution for remote monitoring, with a rotary knob to set PowerControl and PowerAssist levels.



Blue Power Panel

Connects to a Multi or Quattro and all VE.Net devices, in particular the VE.Net Battery Controller. Graphical display of currents and voltages.



Computer controlled operation and monitoring

Several interfaces are available:

- **MK2.2 VE.Bus to RS232 converter**
Connects to the RS232 port of a computer (see 'A guide to VEConfigure')
- **MK2-USB VE.Bus to USB converter**
Connects to a USB port (see 'A guide to VEConfigure')
- **VE.Net to VE.Bus converter**
Interface to VE.Net (see VE.Net documentation)
- **VE.Bus to NMEA 2000 converter**
- **Victron Global Remote**
The Global Remote is a modem which sends alarms, warnings and system status reports to cellular phones via text messages (SMS). It can also log data from Victron Battery Monitors, Multis, Quattros and Inverters to our VRM website through a GPRS connection. Access to this website is free of charge.
- **Victron Ethernet Remote**
To connect to the Ethernet.
- **Color Control panel (see picture on page 1)**
Behind the color LCD a Linux microcomputer runs open source software. The Color Control (CCGX) provides intuitive control and monitoring for all products connected to it. The list of Victron products that can be connected is endless: Inverters, Multis, Quattros, all our latest MPPT solar chargers, BMV-700, BMV-600, Lynx Ion + Shunt and more. The information can also be forwarded to our free remote monitoring website: the VRM Online Portal.



BMV-700 Battery Monitor

The BMV-700 Battery Monitor features an advanced microprocessor control system combined with high resolution measuring systems for battery voltage and charge/discharge current. Besides this, the software includes complex calculation algorithms, like Peukert's formula, to exactly determine the state of charge of the battery. The BMV-700 selectively displays battery voltage, current, consumed Ah or time to go. The monitor also stores a host of data regarding performance and use of the battery. Several models available (see battery monitor documentation).





Blue Power Battery Charger GX IP20

180-265VAC



**Blue Power Battery Charger
GX IP20 12/15**

The highest efficiency ever!

With up to 95% efficiency, these chargers generate up to **four times less heat** when compared to the industry standard.

And once the battery is fully charged, power consumption reduces to 0,5 Watt, some **five to ten times better** than the industry standard.

Adaptive 4-stage charge algorithm: bulk – absorption – float – storage

The Blue Power charger features a microprocessor controlled 'adaptive' battery management. The 'adaptive' feature will automatically optimize the charging process relative to the way the battery is being used.

Less maintenance and aging when the battery is not in use: the Storage Mode

The storage mode kicks in whenever the battery has not been subjected to discharge during 24 hours. In the storage mode float voltage is reduced to 2,2V/cell (13,2V for a 12V battery) to minimize gassing and corrosion of the positive plates. Once a week the voltage is raised back to the absorption level to 'equalize' the battery. This feature prevents stratification of the electrolyte and sulphation, a major cause of early battery failure.

Totally silent

No fan.

Protected against overheating

Output current will reduce as temperature increases up to 60°C, but the Blue Power charger will not fail.

Two LEDs for status indication

Yellow LED: bulk charge (blinking fast), absorption (blinking slow), float (solid), storage (off)

Green LED: power on

Learn more about batteries and battery charging

To learn more about batteries and charging batteries, please refer to our book 'Energy Unlimited' (available free of charge from Victron Energy and downloadable from www.victronenergy.com).

Blue Power Charger GX IP20	12/7 (1) 12/10 (1) 12/15 (1)		24/5 (1) 24/8 (1)	
	Input voltage range	180-265 VAC or 250-350 VDC		
Efficiency	94%		95%	
No load power consumption	0.5 W		0.5 W	
Frequency	45-65 Hz or DC			
Number of outputs	1		1	
Charge voltage 'absorption' (V DC)	14,4		28,8	
Charge voltage 'float' (V DC)	13.8		27.6	
Charge voltage 'storage' (V DC)	13,2		26,4	
Charge current (A)	7 / 10 / 15		5 / 8	
Charge characteristic	4-stage adaptive			
Minimum battery capacity (Ah)	24 / 30 / 45		16 / 24	
Can be used as power supply	Yes			
Protection	Battery reverse polarity (fuse)		Output short circuit Over temperature	
Operating temp. range	-20 to +60°C (full rated output up to 40°C)			
Humidity (non-condensing)	Max 95%			
Cooling	Natural convection (no fan)			
ENCLOSURE				
Material & Colour	Aluminium (blue RAL 5012)			
Battery-connection	Black and red cable of 1,5 meter with battery clamps			
230 V AC-connection	Cable of 1,5 meter with CEE 7/7 plug, BS 1363 plug (UK) or AS/NZS 3112 plug (AU/NZ)			
Protection category	IP20			
Weight (kg)	1,3			
Dimensions (h x w x d in mm)	66 x 90 x 235			
STANDARDS				
Safety	EN 60335-1, EN 60335-2-29			
Emission	EN 55014-1, EN 61000-6-3, EN 61000-3-2			
Immunity	EN 55014-2, EN 61000-6-1, EN 61000-6-2, EN 61000-3-3			

Blue Power Battery Charger GX IP20 12-25 and 24-12

180-265VAC

Adaptive 4-stage charge characteristic: bulk – absorption – float – storage

The Blue Power Charger features a microprocessor controlled 'adaptive' battery management. The 'adaptive' feature will automatically optimize the charging process relative to the way the battery is being used.

Less maintenance and aging when the battery is not in use: the Storage Mode

The storage mode kicks in whenever the battery has not been subjected to discharge during 24 hours. In the storage mode float voltage is reduced to 2,2V/cell (13,2V for a 12V battery) to minimize gassing and corrosion of the positive plates. Once a week the voltage is raised back to the absorption level to 'equalize' the battery. This feature prevents stratification of the electrolyte and sulfation, a major cause of early battery failure.

Protected against overheating and silent fan cooling

Output current will reduce as temperature increases up to 60°C, but the Blue Power Charger will not fail. The load and temperature controlled fan is practically inaudible.

Two LEDs for status indication

Yellow LED: bulk charge (blinking fast), absorption (blinking slow), float (solid), storage (off)
Green LED: power on

Learn more about batteries and battery charging

To learn more about batteries and charging batteries, please refer to our book 'Energy Unlimited' (available free of charge from Victron Energy and downloadable from www.victronenergy.com).



Blue Power Battery Charger
GX IP20 12/25 (1)

Blue Power Charger GX IP20	12/25 (1)	24/12 (1)
Input voltage range	180-265 VAC or 250-350 VDC	
Frequency	45-65 Hz or DC	
Number of outputs	1	1
Charge voltage 'absorption' (V DC)	14,4	28,8
Charge voltage 'float' (V DC)	14	28
Charge voltage 'storage' (V DC)	13,2	26,4
Charge current (A)	25	12 or 15
Charge characteristic	4-stage adaptive	
Minimum battery capacity (Ah)	75	45
Can be used as power supply	Yes	
Protection	Battery reverse polarity (fuse)	Output short circuit Over temperature
Operating temp. range	-20 to +60°C (full rated output up to 40°C)	
Humidity (non condensing)	Max 95%	
Cooling	Fan assisted	
ENCLOSURE		
Material & Colour	Aluminium (blue RAL 5012)	
Battery-connection	One output: black and red cable of 1,5 meter	Three outputs: screw terminals 6 mm ²
230 V AC-connection	Cable of 1,5 meter with CEE 7/7 or AS/NZS 3112 plug	
Protection category	IP 20	
Weight (kg)	1,3	
Dimensions (h x w x d in mm)	66 x 90 x 235	
STANDARDS		
Safety	EN 60335-1, EN 60335-2-29	
Emission	EN 55014-1, EN 61000-6-3, EN 61000-3-2	
Immunity	EN 55014-2, EN 61000-6-1, EN 61000-6-2, EN 61000-3-3	



**Blue Power Battery Charger
IP22 12/30 (3)**

High efficiency

With up to 94% efficiency, these chargers generate up to four times less heat when compared to the industry standard.

And once the battery is fully charged, power consumption reduces to 0,5 Watt, some five to ten times better than the industry standard.

Adaptive 6-stage charge algorithm: test - bulk – absorption - recondition – float – storage

The Blue Power Charger features a microprocessor controlled 'adaptive' battery management. The adaptive feature will automatically optimize the charging process relative to the way the battery is being used.

Storage Mode: less maintenance and aging when the battery is not in use

The storage mode kicks in whenever the battery has not been subjected to discharge during 24 hours. In the storage mode float voltage is reduced to 2,2V/cell (13,2V for a 12V battery) to minimize gassing and corrosion of the positive plates. Once a week the voltage is raised back to the absorption level to 'equalize' the battery. This feature prevents stratification of the electrolyte and sulfation, a major cause of early battery failure.

Also charges Li-ion (LiFePO₄) batteries

LiFePO₄ batteries are charged with a simple bulk – absorption – float algorithm.

NIGHT and LOW setting

When in NIGHT or LOW mode, the output current is reduced to max. 25% of the nominal output and the charger will be totally noiseless. The NIGHT mode automatically ends after 8 hours. The LOW mode can be ended manually.

Protected against overheating

Output current will reduce as temperature increases up to 50°C, but the Blue Power Charger will not fail.

Eleven LEDs for status indication

Charge algorithm: TEST / BULK / ABSORPTION / RECONDITION / FLOAT / STORAGE / READY.

MODE button to set: NORMAL (14,4V) / HIGH (14,7V) / RECONDITION / LI-ION.

Blue Power Charger	12V, 1 output 15 / 20 / 30A	12V, 3 outputs 15 / 20 / 30A	24V, 1 output 8 / 12 / 15A	24V, 3 outputs 8 / 12 / 15A
Input voltage range	180 – 265 VAC			180 – 265 VAC
Charge current, normal mode	15 / 20 / 30 A			8/12/15 A
Charge current, NIGHT or LOW	4 / 5 / 8 A			2 / 3 / 4 A
Efficiency	93%			94%
No load power consumption	0.5 W			0.5 W
Frequency	45 – 65 Hz			45 – 65 Hz
Number of outputs	1	3	1	3
Charge voltage 'absorption'	Normal: 14,4V High: 14,6V	Li-ion: 14,2V	Normal: 28,8V High: 29,2V	Li-ion: 28,4V
Charge voltage 'float'	Normal: 13,8V High: 13,8V	Li-ion: 13,35V	Normal: 27,6V High: 27,6V	Li-ion: 26,7V
Charge voltage 'storage'	Normal: 13,2V High: 13,8V	Li-ion: n. a.	Normal: 26,4V High: 26,4V	Li-ion: n. a.
Charge algorithm	6-stage adaptive			
Can be used as power supply	Yes			
Protection	Battery reverse polarity (fuse)	Output short circuit	Over temperature	
Operating temp. range	-20 to +50°C			
Humidity (non-condensing)	Max 98%			
ENCLOSURE				
Material & Colour	Aluminium (blue RAL 5012)			
Battery connection	Screw terminals 13 mm ² / AWG6			
230 V AC connection	Cable of 1,5 meter with CEE 7/7 plug, BS 1363 plug (UK) or AS/NZS 3112 plug (AU/NZ)			
Protection category	IP22			
Weight	1,3 kg			
Dimensions (h x w x d)	235 x 108 x 65 mm			
STANDARDS				
Safety	EN 60335-1, EN 60335-2-29			
Emission	EN 55014-1, EN 61000-6-3, EN 61000-3-2			
Immunity	EN 55014-2, EN 61000-6-1, EN 61000-6-2, EN 61000-3-3			



**Blue Power Charger
24V 5A IP65**
Completely encapsulated: waterproof, shockproof and ignition protected

Water, oil or dirt will not damage the Blue Power Charger. The casing is made of cast aluminium and the electronics are moulded in resin.

Protected against overheating

It can be used in a hot environment such as a machine room. Output current will reduce as temperature increases up to 60°C, but the Blue Power Charger will not fail.

Automatic three-stage charging

Once the absorption voltage has been reached, the Blue Power Charger will switch to float charge 2 hours after the charge current has reduced to a low break point current (see specifications), or after a 20 hour absorption period. The battery is therefore effectively protected against overcharging and can remain permanently connected to the charger. The charger will automatically reset and start a new charge cycle after interruption of the AC supply or after reduction of the output voltage to 12 V resp. 24 V due to a DC load.

Two LEDs for status indication

Yellow LED: battery being charged

Yellow LED and Green LED: absorption charge

Green LED: float charge, the battery is charged

Learn more about batteries and battery charging

To learn more about batteries and charging batteries, please refer to our book 'Energy Unlimited' (available free of charge from Victron Energy and downloadable from www.victronenergy.com).

Blue Power charger Waterproof	12/7	24/5
Input voltage range (V AC)	200-265	
Frequency (Hz)	45-65	
Charge voltage 'absorption' (V DC)	14,4	28,8
Charge voltage 'float' (V DC)	13,7	27,4
Charge current (A)	7	5
Charge characteristic	3 stage with max. 18 hours absorption time	
Minimum battery capacity (Ah)	15	10
Breakpoint current (A)	0,7	0,3
Can be used as power supply	√	√
Protection (1)	a,b,c,	
Operating temp. range	-20 to +60°C (full rated output up to 40°C)	
Humidity	Up to 100%	
ENCLOSURE		
Material & Colour	aluminium (blue RAL 5012)	
Battery-connection	Black and red cable of 1,5 meter	
230 V AC-connection (2)	Cable of 1,5 meter with CEE 7/7 or AS/NZS 3112 plug	
Protection category	IP 65	
Weight (kg)	1,1	
Dimensions (h x w x d in mm)	43 x 80 x 155	
STANDARDS		
Safety	EN 60335-1, EN 60335-2-29	
Emission Immunity	EN 55014-1, EN 61000-6-3, EN 61000-3-2	
Automotive Directive	EN 55014-2, EN 61000-6-1, EN 61000-6-2, EN 61000-3-3	
1) Protection key: a) Battery reverse polarity (fuse in battery cable) b) Output short circuit c) Over temperature	2) Other plug types on request	



**Blue Power Charger
IP67 12/25**

Completely encapsulated: waterproof, shockproof and ignition protected

Water, oil or dirt will not damage the Blue Power IP67 Charger. The casing is made of cast aluminium and the electronics are moulded in resin.

Start interrupt

The models with suffix (1+Si) feature a second current limited output which is always powered as long as 180 – 265 VAC is present on the input. This output can for example be used to prevent starting of a vehicle before unplugging the battery charger (start interrupt function).

The highest efficiency ever!

Setting a new industry standard: with 92% efficiency or better, these chargers waste three to four times less heat.

And once the battery is fully charged, power consumption reduces to less than a Watt, some five to ten times better than the industry standard.

Adaptive 4-stage charge algorithm: bulk – absorption – float – storage

The Blue Power Charge features a microprocessor controlled 'adaptive' battery management. The 'adaptive' feature will automatically optimise the charging process relative to the way the battery is being used.

Less maintenance and aging when the battery is not in use: the Storage Mode

The storage mode kicks in whenever the battery has not been subjected to discharge during 24 hours. In the storage mode float voltage is reduced to 2,2 V/cell (13,2 V for a 12 V battery) to minimise gassing and corrosion of the positive plates. Once a week the voltage is raised back to the absorption level to 'equalize' the battery. This feature prevents stratification of the electrolyte and sulphation, a major cause of early battery failure.

Protected against overheating

Can be used in a hot environment such as a machine room. Output current will reduce as temperature increases up to 60°C, but the charger will not fail.

Two LEDs for status indication

Yellow LED: bulk charge (blinking fast), absorption (blinking slow), float (solid), storage (off)

Green LED: power on

Blue Power charger IP67	12/7	12/13	12/17	12/25	24/5	24/8	24/12
Input voltage range and frequency	180-265 VAC 45-65 Hz						
Efficiency	93%	93%	95%	95%	94%	96%	96%
No load power consumption (W)	0.5	0.5	0.5	0.5	0.5	0.5	0.5
Charge voltage 'absorption' (V DC)	14,4	14,4	14,4	14,4	28,8	28,8	28,8
Charge voltage 'float' (V DC)	13,7	13,7	13,7	13,7	27,6	27,6	27,6
Charge voltage 'storage' (V DC)	13,2	13,2	13,2	13,2	26,4	26,4	26,4
Charge current (A)	7	13	17	25	5	8	12
Charge algorithm	4-stage adaptive						
Can be used as power supply	yes						
Protection	Battery reverse polarity (fuse)		Output short circuit		Over temperature		
Operating temp. range	-20 to +60°C (full rated output up to 40°C)						
Humidity	Up to 100%						
Start interrupt option (Si)	Short circuit proof, current limit 0,5 A Output voltage: max one volt lower than main output						
ENCLOSURE							
Material & Colour	aluminium (blue RAL 5012)						
Battery-connection	Black and red cable of 1,5 meter						
230 V AC-connection	Cable of 1,5 meter with CEE 7/7 plug						
Protection category	IP67						
Weight (kg)	1,8	1,8	2,4	2,4	1,8	2,4	2,4
Dimensions (h x w x d in mm)	85 x 211 x 60	85 x 211 x 60	99 x 219 x 65	99 x 219 x 65	85 x 211 x 60	99 x 219 x 65	99 x 219 x 65
STANDARDS							
Safety	EN 60335-1, EN 60335-2-29						
Emission Immunity	EN 55014-1, EN 61000-6-3, EN 61000-3-2						
Automotive Directive	EN 55014-2, EN 61000-6-1, EN 61000-6-2, EN 61000-3-3						

Blue Smart IP 65 Charger

Blue Smart Charger IP65	12 V 5/7/10/15 A	24 V 5/8 A
Input voltage range	180-265 VAC	
Efficiency	94%	95%
Standby power consumption	0,5 W	
Charge voltage 'absorption'	Normal: 14,4 V High: 14,7 V Li-ion: 14,2 V	Normal: 28,8 V High: 29,4 V Li-ion: 28,4 V
Charge voltage 'float'	Normal: 13,8 V High: 13,8 V Li-ion: 13,5 V	Normal: 27,6 V High: 27,6 V Li-ion: 27,0 V
Charge voltage 'storage'	Normal: 13,2 V High: 13,2 V Li-ion: 13,5 V	Normal: 26,4 V High: 26,4 V Li-ion: 27,0 V
Charge current	5 / 7 / 10 / 15 A	5 / 8 A
Low current mode	2 / 2 / 3 / 4 A	2 / 3 A
Temperature compensation (lead-acid batteries only)	16 mV/°C	32 mV/°C
Can be used as power supply	Yes	
Back current drain	0,7 Ah/month (1 mA)	
Protection	Reverse polarity Output short circuit Over temperature	
Operating temp. range	-30 to +50°C (full rated output up to 30°C) (cables retain flexibility at low temperature)	
Humidity (non condensing)	Max 95 %	
ENCLOSURE		
Battery-connection	Black and red cable of 1,5 meter with 20 A DC connector, clamps and M8 eyelets	
230 V AC-connection	Cable of 1,5 meter with CEE 7/17, BS 1363 plug (UK) or AS/NZS 3112 plug	
Protection category	IP65 (splash and dust proof)	
Weight	0,9 kg	0,9 kg
Dimensions (h x w x d)	12/7: 47x95x190mm Other: 60x105x190mm	24/5: 47x95x190mm 24/8: 60x105x190mm
STANDARDS		
Safety	EN 60335-1, EN 60335-2-29	
Emission	EN 55014-1, EN 61000-6-3, EN 61000-3-2	
Immunity	EN 55014-2, EN 61000-6-1, EN 61000-6-2, EN 61000-3-3	
www.victronenergy.com Customer support: sales@victronenergy.com		

Included

Clamps



M8 eyelets



Optional

Fused clamps



Fused M6 eyelets



Extension cable, 2 m



Autoplug



Blue Smart Charger

IP65

The professional's choice









- Water, dust and chemical resistant
- Seven step smart charge algorithm
- Recovery of fully discharged 'dead' batteries
- Automatic power supply function
- Severe cold performance: down to -30°C
- Several other battery life enhancing features
- Low power mode to charge smaller batteries
- **Li-ion** battery mode
- Setup and configure, readout of voltage and current by **Bluetooth Smart**



IP65 - Charger Guide

Blue Smart IP65 Charger



Battery size Ah	12V				24V	
	5 A 20 - 50 Ah	7 A 20 - 50 Ah	10 A 30 - 70 Ah	15 A 50 - 150 Ah	5 A 20 - 50 Ah	8 A 30 - 70 Ah
Your IP65 Charger »	12/5	12/7	12/10	12/15	24/5	24/8
	●	●	●	●		
	●	●	●	●		
CLASSIC 	●	●	●	●		
MODERN 	●	●	●	●		
	●	●	●	●	●	●
					●	●
	●	●	●	●	●	●

● **Recommended**

This is the best charger for this type of battery. The battery will be charged in the most efficient way.

● **OK**

This charger can be used for this battery. It is possible that it takes longer to charge the battery than using a recommended charger.

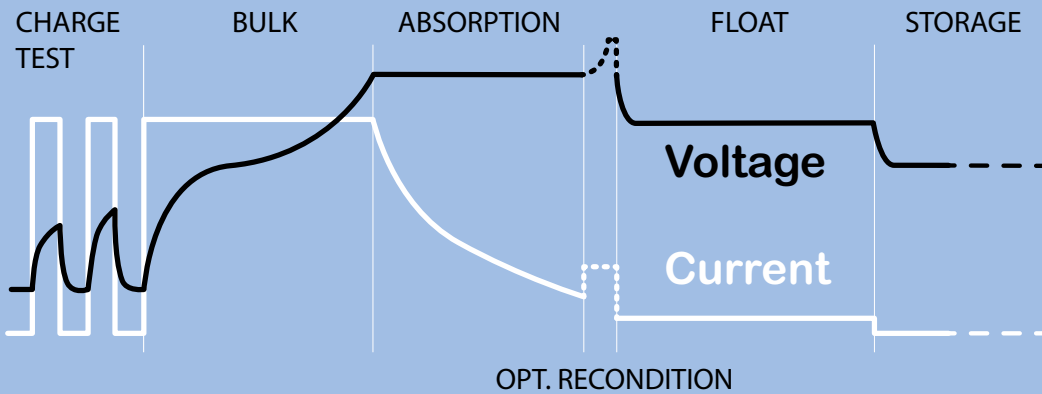

Reconditioning

A lead-acid battery that has been insufficiently charged or has been left discharged during days or weeks will deteriorate due to sulfation. If caught in time, sulfation can sometimes be partially reversed by charging the battery with low current up to a higher voltage.

Recovery function for fully discharged batteries

Most reverse polarity protected chargers will not recognize, and therefore not recharge a battery which has been discharged to zero or nearly zero Volts. The **Blue Smart Charger** however will attempt to recharge a fully discharged battery with low current and resume normal charging once sufficient voltage has developed across the battery terminals.

Ultra high efficiency "green" battery charger

With up to 95% efficiency, these chargers generate up to four times less heat when compared to the industry standard. And once the battery is fully charged, power consumption reduces to 0,5 Watt, some five to ten times better than the industry standard.



The VictronConnect app

Setup, readout and configure your **Blue Smart IP65 Charger** via your smartphone.

You can display the status of your charger and battery and even control the functions of your charger using the VictronConnect app. On your screen the readout of voltage and current is default available.

Download your app for iOS and Android here at

<https://www.victronenergy.com/live/victronconnect>

Durable, safe and silent

- Low thermal stress on the electronic components.
- Protection against ingress of dust, water and chemicals.
- Protection against overheating: the output current will reduce as temperature increases up to 60°C, but the charger will not fail.
- The chargers are totally silent: no cooling fan or any other moving parts.



STORAGE

REFRESH

STORAGE



1 week

Storage mode: less corrosion of the positive plates

Even the lower float charge voltage that follows the absorption period will cause grid corrosion. It is therefore essential to reduce the charge voltage even further when the battery remains connected to the charger during more than 48 hours

Temperature compensated charging

The optimal charge voltage of a lead-acid battery varies inversely with temperature. The **Blue Smart IP65 Charger** measures ambient temperature during the test phase and compensates for temperature during the charge process. The temperature is measured again when the charger is in low current mode during float or storage. Special settings for a cold or hot environment are therefore not needed.

Li-ion battery mode

The **Blue Smart Charger** uses a specific charging algorithm for Li-ion (LiFePO₄) batteries, with automatic Li-ion under voltage protection reset.

Blue Power IP 65 Charger

Blue Power Charger IP65	12 V 5/7/10/15 A	24 V 5/8 A
Input voltage range	180-265 VAC	
Efficiency	94%	95%
Standby power consumption	0,5 W	
Charge voltage 'absorption'	Normal: 14,4 V High: 14,7 V Li-ion: 14,2 V	Normal: 28,8 V High: 29,4 V Li-ion: 28,4 V
Charge voltage 'float'	Normal: 13,8 V High: 13,8 V Li-ion: 13,5 V	Normal: 27,6 V High: 27,6 V Li-ion: 27,0 V
Charge voltage 'storage'	Normal: 13,2 V High: 13,2 V Li-ion: 13,5 V	Normal: 26,4 V High: 26,4 V Li-ion: 27,0 V
Charge current	5 / 7 / 10 / 15 A	5 / 8 A
Low current mode	2 / 2 / 3 / 4 A	2 / 3 A
Temperature compensation (lead-acid batteries only)	16 mV/°C	32 mV/°C
Can be used as power supply	Yes	
Back current drain	0,7 Ah/month (1 mA)	
Protection	Reverse polarity Output short circuit Over temperature	
Operating temp. range	-30 to +50°C (full rated output up to 30°C) (cables retain flexibility at low temperature)	
Humidity (non condensing)	Max 95 %	
ENCLOSURE		
Battery-connection	Black and red cable of 1,5 meter with 20 A DC connector, clamps and M8 eyelets	
230 V AC-connection	Cable of 1,5 meter with CEE 7/17, BS 1363 plug (UK) or AS/NZS 3112 plug	
Protection category	IP65 (splash and dust proof)	
Weight	0,9 kg	0,9 kg
Dimensions (h x w x d)	12/7: 47x95x190mm Other: 60x105x190mm	24/5: 47x95x190mm 24/8: 60x105x190mm
STANDARDS		
Safety	EN 60335-1, EN 60335-2-29	
Emission	EN 55014-1, EN 61000-6-3, EN 61000-3-2	
Immunity	EN 55014-2, EN 61000-6-1, EN 61000-6-2, EN 61000-3-3	
www.victronenergy.com Customer support: sales@victronenergy.com		

Included

Clamps

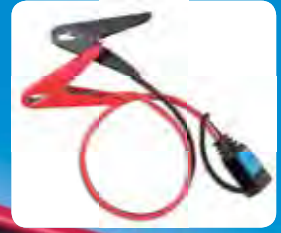

M8 eyelets



Optional

Fused clamps



Fused M6 eyelets



Extension cable, 2 m



Autoplug



Blue Power Charger

IP65

The professional's choice

5
Year
WARRANTY



- Water, dust and chemical resistant
- Seven step smart charge algorithm
- Recovery of fully discharged 'dead' batteries
- Automatic power supply function
- Severe cold performance: down to -30°C
- Several other battery life enhancing features
- Low power mode to charge smaller batteries
- **Li-ion** battery mode



victron energy
BLUE POWER

IP65 - Charger Guide

Blue Power IP65 Charger



Battery size Ah	12V				24V	
	5 A 20 - 50 Ah	7 A 20 - 50 Ah	10 A 30 - 70 Ah	15 A 50 - 150 Ah	5 A 20 - 50 Ah	8 A 30 - 70 Ah
Your IP65 Charger »	12/5	12/7	12/10	12/15	24/5	24/8
MOTORCYCLE	Recommended	OK	OK	OK		
CLASSIC	Recommended	Recommended	OK	OK		
MODERN	Recommended	Recommended	Recommended	Recommended		
VAN	Recommended	Recommended	Recommended	Recommended	OK	OK
TRUCK					Recommended	Recommended
BOAT	OK	OK	OK	Recommended	OK	Recommended

Recommended

This is the best charger for this type of battery. The battery will be charged in the most efficient way.

OK

This charger can be used for this battery. It is possible that it takes longer to charge the battery than using a recommended charger for this type of battery.

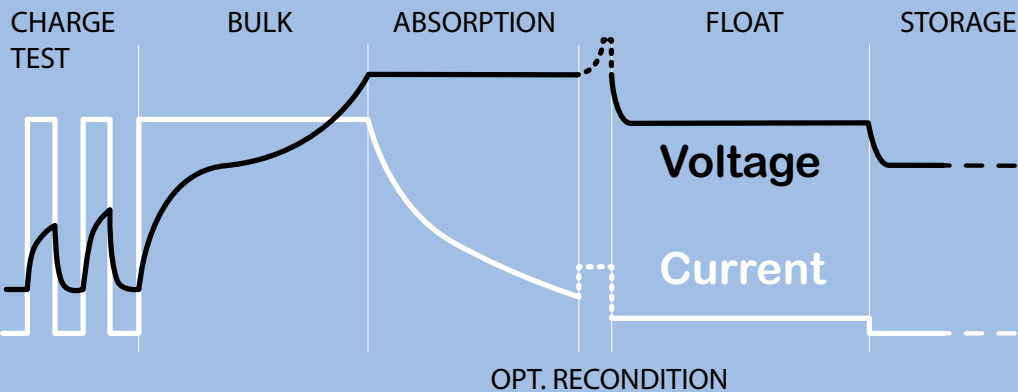

Reconditioning

A lead-acid battery that has been insufficiently charged or has been left discharged during days or weeks will deteriorate due to sulfation. If caught in time, sulfation can sometimes be partially reversed by charging the battery with low current up to a higher voltage.

Recovery function for fully discharged batteries

Most reverse polarity protected chargers will not recognize, and therefore not recharge a battery which has been discharged to zero or nearly zero Volts. The **Blue Power Charger** however will attempt to recharge a fully discharged battery with low current and resume normal charging once sufficient voltage has developed across the battery terminals.



Ultra high efficiency “green” battery charger

With up to 95% efficiency, these chargers generate up to four times less heat when compared to the industry standard. And once the battery is fully charged, power consumption reduces to 0,5 Watt, some five to ten times better than the industry standard.

Durable, safe and silent

- Low thermal stress on the electronic components.
- Protection against ingress of dust, water and chemicals.
- Protection against overheating: the output current will reduce as temperature increases up to 60°C, but the charger will not fail.
- The chargers are totally silent: no cooling fan or any other moving parts.

Storage mode: less corrosion of the positive plates

Even the lower float charge voltage that follows the absorption period will cause grid corrosion. It is therefore essential to reduce the charge voltage even further when the battery remains connected to the charger during more than 48 hours.

STORAGE

REFRESH

STORAGE



1 week

Temperature compensated charging

The optimal charge voltage of a lead-acid battery varies inversely with temperature.

The Blue Power IP65 Charger measures ambient temperature during the test phase and compensates for temperature during the charge process. The temperature is measured again when the charger is in low current mode during float or storage. Special settings for a cold or hot environment are therefore not needed.

Li-ion battery mode

The **Blue Power Charger** uses a specific charging algorithm for Li-ion (LiFePO₄) batteries, with automatic Li-ion under voltage protection reset.





**Centaur
Battery Charger 24 30**

Quality without compromise

Aluminium epoxy powder coated cases with drip shield and stainless steel fixings withstand the rigors of an adverse environment: heat, humidity and salt air.
 Circuit boards are protected with an acrylic coating for maximum corrosion resistance.
 Temperature sensors ensure that power components will always operate within specified limits, if needed by automatic reduction of output current under extreme environmental conditions.

Universal 90-265V AC input voltage range and also suitable for DC supply (AC-DC and DC-DC operation)

All models will operate without any adjustment needed over a 90 to 265 Volt input voltage range, whether 50 Hz or 60 Hz.

The chargers also accept a 90-400 V DC supply.

Three outputs that each can supply the full output current

Three isolated outputs to simultaneously charge 3 battery banks
 Each output is capable to supply the full rated current.

Three-stage charging, with temperature compensation

The Centaur charges at bulk rate until the output has reduced to 70% of the rated Amps, at which a 4 hour timer begins. After the timed period the charger switches to float rate.

An internal temperature sensor is used to compensate the charge voltage with $-2 \text{ mV}/^{\circ}\text{C}$ ($-1 \text{ mV}/^{\circ}\text{F}$) per cell.
 A DIP switch is available to select the optimum charge/float voltages for Flooded Lead-acid, Gel or AGM batteries.

Learn more about batteries and battery charging

To learn more about batteries and charging batteries (including the pro's and cons of multi-bank charging and intelligent charging), please refer to our book 'Electricity on Board' (available free of charge from Victron Energy and downloadable from www.victronenergy.com).

Charge curve

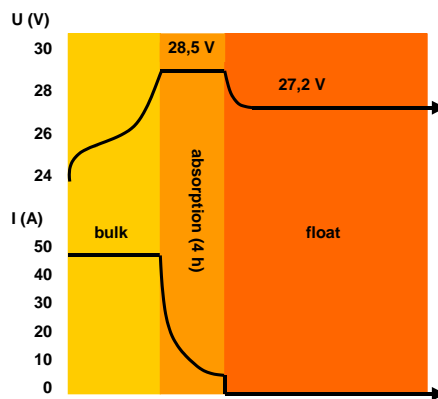

Application example

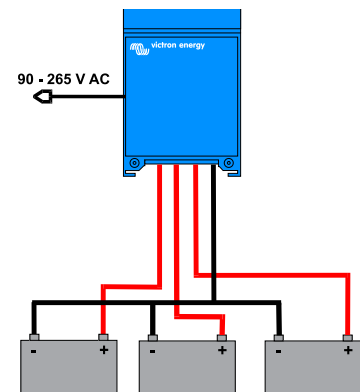

Centaur Charger	12/20	12/30 24/16	12/40	12/50	12/60 24/30	12/80 24/40	12/100 24/60
Input voltage (V AC)	90 – 265						
Input voltage (V DC)	90 – 400						
Input frequency (Hz)	45 – 65						
Power factor	1						
Charge voltage 'absorption' (V DC)	14,3 / 28,5 (1)						
Charge voltage 'float' (V DC)	13,5 / 27,0 (1)						
Output banks	3						
Charge current (A) (2)	20	30 / 16	40	50	60 / 30	80 / 40	100 / 60
Total output ammeter	Yes						
Charge characteristic	IUoU (Three stage charging)						
Recommended battery capacity (Ah)	80 - 200	120 - 300 45 - 150	160 - 400	200 - 500	240 - 600 120 - 300	320 - 800 160 - 400	400 - 1000 240 - 600
Temperature sensor	Internal, - 2mV / °C (- 1mV / °F) per cell						
Forced cooling	Yes, temperature and current controlled fan						
Protection	Output short circuit, over temperature						
Operating temp. range	- 20 to 60°C (0 - 140°F)						
Ignition protected	Yes						
Humidity (non condensing)	max 95%						
ENCLOSURE							
Material & Colour	aluminium (blue RAL 5012)						
Battery-connection	M6 studs	M6 studs	M8 studs	M8 studs	M8 studs	M8 studs	M8 studs
AC-connection	screw-clamp 4 mm ² (AWG 6)						
Protection category	IP 20						
Weight kg (lbs)	3,8 (8.4)	3,8 (8.4)	5 (11)	5 (11)	5 (11)	12 (26)	12 (26)
Dimensions hwxwd in mm (hwxwd in inches)	355x215x110 (14.0x8.5x4.3)	355x215x110 (14.0x8.5x4.3)	426x239x135 (16.8x9.4x5.3)	426x239x135 (16.8x9.4x5.3)	426x239x135 (16.8x9.4x5.3)	505x255x130 (19.9x10.0x5.2)	505x255x130 (19.9x10.0x5.2)
STANDARDS							
Safety	EN 60335-1, EN 60335-2-29, UL 1236						
Emission Immunity	EN 55014-1, EN 61000-3-2						
Automotive Directive	EN 55014-2, EN 61000-3-3						
1) Standard setting. Optimum charge/float voltages for Flooded Lead-acid, Gel-Cell or AGM batteries selectable by DIP switch.							
2) Up to 40°C (100°F) ambient. Output will reduce to approximately 80% of nominal at 50°C (120°F) and 60% of nominal at 60°C (140°F).							



BMV-700 Battery Monitor

The BMV-700 Battery Monitor features an advanced microprocessor control system combined with high resolution measuring systems for battery voltage and charge/discharge current. Besides this, the software includes complex calculation algorithms, like Peukert's formula, to exactly determine the state of charge of the battery. The BMV-700 selectively displays battery voltage, current, consumed Ah or time to go.



Battery Alarm

An excessively high or low battery voltage is indicated by an audible and visual alarm.

Installation made easy

1. Fasten the separate mounting plate (A) to the wall where you want to place the battery charger, and simply hook up the Centaur.
2. Secure the bottom of the backside (B) to the wall.



**Phoenix Charger
12 V 30 A**

**Phoenix Charger
24 V 25 A**
Adaptive 4-stage charge characteristic: bulk – absorption – float – storage

The Phoenix Charger features a microprocessor controlled 'adaptive' battery management system that can be preset to suit different types of batteries. The 'adaptive' feature will automatically optimise the process relative to the way the battery is being used.

The right amount of charge: variable absorption time

When only shallow discharges occur (a yacht connected to shore power for example) the absorption time is kept short in order to prevent overcharging of the battery. After a deep discharge the absorption time is automatically increased to make sure that the battery is completely recharged.

Preventing damage due to excessive gassing: the BatterySafe mode (see fig. 2 below)

If, in order to quickly charge a battery, a high charge current in combination with a high absorption voltage has been chosen, the Phoenix Charger will prevent damage due to excessive gassing by automatically limiting the rate of voltage increase once the gassing voltage has been reached (see the charge curve between 14,4 V and 15,0 V in fig. 2 below).

Less maintenance and aging when the battery is not in use: the Storage mode (see fig. 1 & 2 below)

The storage mode kicks in whenever the battery has not been subjected to discharge during 24 hours. In the storage mode float voltage is reduced to 2,2 V/cell (13,2 V for 12 V battery) to minimize gassing and corrosion of the positive plates. Once a week the voltage is raised back to the absorption level to 'equalize' the battery. This feature prevents stratification of the electrolyte and sulphation, a major cause of early battery failure.

To increase battery life: temperature compensation

Every Phoenix Charger comes with a battery temperature sensor. When connected, charge voltage will automatically decrease with increasing battery temperature. This feature is especially recommended for sealed batteries and/or when important fluctuations of battery temperature are expected.

Battery voltage sense

In order to compensate for voltage loss due to cable resistance, Phoenix Chargers are provided with a voltage sense facility so that the battery always receives the correct charge voltage.

Universal 90-265 V AC input voltage range and also suitable for DC supply (AC-DC and DC-DC operation)

The chargers will accept a 90-400 V DC supply.

Computer interface

Every Phoenix Charger is ready to communicate with a computer through its RS-485 data port. Together with our VEConfigure software, which can be downloaded free of charge from our website www.victronenergy.com and the data link MK1b (see accessories), all parameters of the chargers can be customised.

Learn more about batteries and battery charging

To learn more about batteries and charging batteries, please refer to our book 'Energy Unlimited' (available free of charge from Victron Energy and downloadable from www.victronenergy.com). For more information about adaptive charging please look under Technical Information on our website.

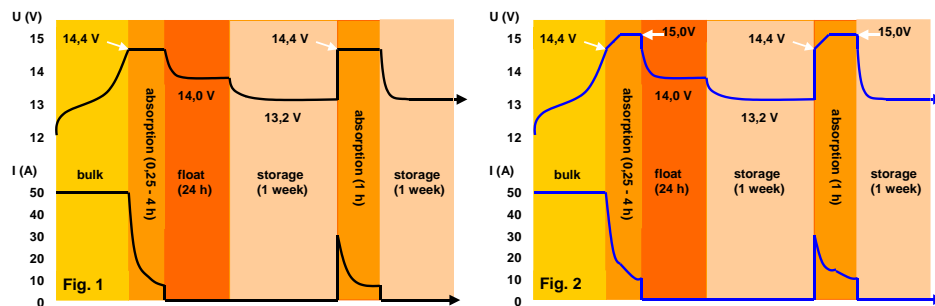
Charge curves: up to the gassing voltage (fig.1), and exceeding the gassing voltage (fig.2)

Phoenix Charger	12/30	12/50	24/16	24/25
Input voltage range (V AC)	90-265			
Input voltage range (V DC)	90-400			
Frequency (Hz)	45-65			
Power factor	1			
Charge voltage 'absorption' (V DC)	14,4	14,4	28,8	28,8
Charge voltage 'float' (V DC)	13,8	13,8	27,6	27,6
Storage mode (V DC)	13,2	13,2	26,4	26,4
Charge current house batt. (A) (2)	30	50	16	25
Charge current starter batt. (A)	4	4	4	4
Charge characteristic	4 stage adaptive			
Battery capacity (Ah)	100-400	200-800	100-200	100-400
Temperature sensor	√	√	√	√
Can be used as power supply	√	√	√	√
Forced cooling	√	√	√	√
Protection (1)	a,b,c,d			
Operating temp. range	-20 to 60°C (0 - 140°F)			
Humidity (non-condensing)	max 95%			
ENCLOSURE				
Material & Colour	aluminium (blue RAL 5012)			
Battery-connection	M6 studs			
AC-connection	screw-clamp 4 mm ² (AWG 11)			
Protection category	IP 21			
Weight kg (lbs)	3,8 (8)			
Dimensions (hwxwd in mm and inches)	350x200x108 mm (13.8x7.9x4.3 inch)			
STANDARDS				
Safety	EN 60335-1, EN 60335-2-29			
Emission Immunity	EN 55014-1, EN 61000-3-2,			
Automotive Directive	EN 55014-2, EN 61000-3-3			
Vibration	IEC68-2-6:10-150Hz/1.0G			
1) Protection key: a) Output short circuit b) Battery reverse polarity detection	c) Battery voltage too high d) Temperature too high		2) Up to 40°C (100°F) ambient	



Battery Alarm

An excessively high or low battery voltage is indicated by an audible and visual alarm, and potential free contacts.



Phoenix Charger Control

The PCC panel provides remote control and monitoring of the charge process with LED indication of the charger status. In addition, the remote panel also offers output current adjustment that can be used to limit the output current and thus the power drawn from the AC supply. This is particularly useful when operating the charger from limited shore power or small gensets. The panel can also be used to change the battery charging parameters.

The brightness of the LEDs is automatically reduced during night time. Connection to the charger is with a standard UTP-cable.



BMV-700 Battery Monitor

The BMV-700 Battery Monitor features an advanced microprocessor control system combined with high resolution measuring systems for battery voltage and charge/discharge current. Besides this, the software includes complex calculation algorithms, like Peukert's formula, to exactly determine the state of charge of the battery. The BMV-700 selectively displays battery voltage, current, consumed Ah or time to go.

Skylla-i 24/100 (3)
Skylla-i (1+1): two outputs to charge 2 battery banks

The Skylla-i (1+1) features 2 isolated outputs. The second output, limited to approximately 4 A and with a slightly lower output voltage, is intended to top up a starter battery.

Skylla-i (3): three full current outputs to charge 3 battery banks

The Skylla-i (3) features 3 isolated outputs. All outputs can supply the full rated output current.

Rugged

Aluminium epoxy powder coated cases with drip shield and stainless steel fixings withstand the rigors of an adverse environment: heat, humidity and salt air. Circuit boards are protected with an acrylic coating for maximum corrosion resistance. Temperature sensors ensure that power components will always operate within specified limits, if needed by automatic reduction of output current under extreme environmental conditions.

Flexible

Next to a CAN bus (NMEA2000) interface, a rotary switch, DIP switches and potentiometers are available to adapt the charge algorithm to a particular battery and its conditions of use. Please refer to the manual for a complete overview of the possibilities.

Important features:
Synchronised parallel operation

Several chargers can be synchronised with the CAN bus interface. This is achieved by simply interconnecting the chargers with RJ45 UTP-cables. Please see the manual for details.

The right amount of charge for a lead-acid battery: variable absorption time

When only shallow discharges occur the absorption time is kept short in order to prevent overcharging of the battery. After a deep discharge the absorption time is automatically increased to make sure that the battery is completely recharged.

Preventing damage due to excessive gassing: the BatterySafe mode

If, in order to quickly charge a battery, a high charge current in combination with a high absorption voltage has been chosen, the Skylla-i will prevent damage due to excessive gassing by automatically limiting the rate of voltage increase once the gassing voltage has been reached.

Less maintenance and aging when the battery is not in use: the Storage mode

The storage mode kicks in whenever the battery has not been subjected to discharge during 24 hours. In the storage mode float voltage is reduced to 2,2 V/cell (26,4 V for 24 V battery) to minimise gassing and corrosion of the positive plates. Once a week the voltage is raised back to the absorption level to 'refresh' the battery. This feature prevents stratification of the electrolyte and sulphation, a major cause of early battery failure.

To increase battery life: temperature compensation

Every Skylla-i comes with a battery temperature sensor. When connected, charge voltage will automatically decrease with increasing battery temperature. This feature is especially recommended for sealed lead-acid batteries and/or when important fluctuations of battery temperature are expected.

Battery voltage sense

In order to compensate for voltage loss due to cable resistance, the Skylla-i is provided with a voltage sense facility so that the battery always receives the correct charge voltage.

Suitable for AC and DC supply (AC-DC and DC-DC operation)

The chargers also accept a DC supply.

Use as a power supply

As a result of the perfectly stabilized output voltage, the Skylla-i can be used as a power supply if batteries or large buffer capacitors are not available.

Li-Ion (LiFePO4) ready

Simple charger on-off control can be implemented by connecting a relay or open collector optocoupler output from a Li-Ion BMS to the remote control port of the charger. Alternatively complete control of voltage and current can be achieved by connecting to the galvanically isolated CAN bus port.

Learn more about batteries and battery charging

To learn more about batteries and charging batteries, please refer to our book 'Energy Unlimited' (available free of charge from Victron Energy and downloadable from www.victronenergy.com).

Skylla-i 24/100 (1+1)

Skylla-i	24/80 (1+1)	24/80 (3)	24/100 (1+1)	24/100 (3)
Input voltage (VAC)	230 V			
Input voltage range (VAC)	185-265 V			
Input voltage range (VDC)	180-350 V			
Maximum AC input current @ 180 VAC	16 A		20 A	
Frequency (Hz)	45-65 Hz			
Power factor	0,98			
Charge voltage 'absorption' (VDC) (1)	28,8 V			
Charge voltage 'float' (VDC)	27,6 V			
Charge voltage 'storage' (VDC)	26,4 V			
Charge current (A) (2)	80 A	3 x 80 A (max total output: 80A)	100 A	3 x 100 A (max total output: 100A)
Charge current starter batt. (A)	4 A	n. a.	4	n. a.
Charge algorithm	7 stage adaptive			
Battery capacity (Ah)	400-800 Ah		500-1000 Ah	
Charge algorithm, Li-Ion	3 stage, with on-off control or CAN bus control			
Temperature sensor	Yes			
Can be used as power supply	Yes			
Remote on-off port	Yes (can be connected to a Li-Ion BMS)			
CAN bus communication port (VE.Can)	Two RJ45 connectors, NMEA2000 protocol, galvanically isolated			
Synchronised parallel operation	Yes, with VE.Can			
Alarm relay	DPST	AC rating: 240VAC/4A	DC rating: 4A up to 35VDC, 1A up to 60VDC	
Forced cooling	Yes			
Protection	Battery reverse polarity (fuse)		Output short circuit	Over temperature
Operating temp. range	-20 to 60°C (Full output current up to 40°C)			
Humidity (non-condensing)	max 95%			
ENCLOSURE				
Material & Colour	aluminium (blue RAL 5012)			
Battery-connection	M8 bolts			
230 VAC-connection	screw-clamp 10mm ² (AWG 7)			
Protection category	IP 21			
Weight kg (lbs)	7 kg (16 lbs)			
Dimensions hwxwd in mm (hwxwd in inches)	405 x 250 x 150 mm (16.0 x 9.9 x 5.9 inch)			
STANDARDS				
Safety	EN 60335-1, EN 60335-2-29			
Emission	EN 55014-1, EN 61000-6-3, EN 61000-3-2			
Immunity	EN 55014-2, EN 61000-6-1, EN 61000-6-2, EN 61000-3-3			
1) Output voltage range 20-36 V. Can be set with rotary switch or potentiometers.		2) Up to 40°C (100°F) ambient. Output will reduce to 80% at 50°C, and to 60% at 60°C.		



BMV-700 Battery Monitor

The BMV-700 Battery Monitor features an advanced microprocessor control system combined with high resolution measuring systems for battery voltage and charge/discharge current.

The software includes complex calculation algorithms, like Peukert's formula, to exactly determine the state of charge of the battery. The BMV-700 selectively displays battery voltage, battery current, consumed Ah or time to go.



Skylla-i Control

The Skylla-i Control panel provides remote control and monitoring of the charge process with LED status indication. In addition, the remote panel also offers input current adjustment that can be used to limit the input current and thus the power drawn from the AC supply. This is particularly useful when operating the charger from limited shore power or small gensets. The panel can also be used to change several battery charging parameters.

Several control panels can be connected to one charger or to a set of synchronised and parallel connected chargers.

Skylla TG 24 50
Perfect chargers for any type of battery

Charge voltage can be precisely adjusted to suit any sealed or unsealed battery system. In particular, sealed maintenance free batteries must be charged correctly in order to ensure a long service life. Overvoltage will result in excessive gassing and venting of a sealed battery. The battery will dry out and fail.

Suitable for AC and DC supply (AC-DC and DC-DC operation)

Except for the 3-phase input models, the chargers also accept a DC supply.

Controlled charging

Every TG Charger has a microprocessor, which accurately controls the charging in three steps. The charging process takes place in accordance with the IUoUo characteristic and charges more rapidly than other processes.

Use of TG Chargers as a power supply

As a result of the perfectly stabilized output voltage, a TG Charger can be used as a power supply if batteries or large buffer capacitors are not available.

Two outputs to charge 2 battery banks (24 V models only)

The TG Chargers feature 2 isolated outputs. The second output, limited to approximately 4 A and with a slightly lower output voltage, is intended to top up a starter battery.

To increase battery life: temperature compensation

Every Skylla TG Charger comes with a battery temperature sensor. When connected, charge voltage will automatically decrease with increasing battery temperature. This feature is especially recommended for sealed batteries which otherwise might be overcharged and dry out due to venting.

Battery voltage sense

In order to compensate for voltage loss due to cable resistance, TG Chargers are provided with a voltage sense facility so that the battery always receives the correct charge voltage.

Learn more about batteries and battery charging

To learn more about batteries and charging batteries, please refer to our book 'Energy Unlimited' (available free of charge from Victron Energy and downloadable from www.victronenergy.com).

Skylla TG 24 50 3 phase

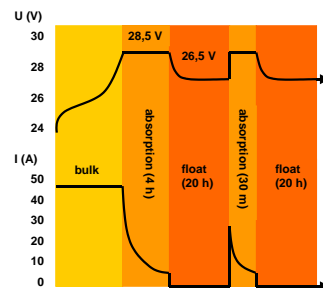
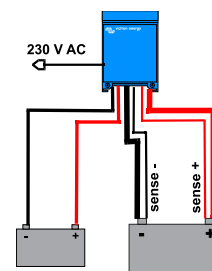
Skylla TG 24 100
Charge curve

Application example

Skylia	24/30 TG 24/50 TG	24/50 TG 3 phase	24/80 TG	24/100 TG	24/100 TG 3 phase	48/25 TG	48/50 TG
Input voltage (V AC)	230	3 x 400	230	230	3 x 400	230	230
Input voltage range (V AC)	185-264	320-450	185-264	185-264	320-450	185-264	185-264
Input voltage range (V DC)	180-400	n. a.	180-400	180-400	n. a.	180-400	180-400
Frequency (Hz)	45-65						
Power factor	1						
Charge voltage 'absorption' (V DC)	28,5	28,5	28,5	28,5	28,5	57	57
Charge voltage 'float' (V DC)	26,5	26,5	26,5	26,5	26,5	53	53
Charge current house batt. (A) (2)	30 / 50	50	80	100	100	25	50
Charge current starter batt. (A)	4	4	4	4	4	n. a.	n. a.
Charge characteristic	IUoUo (three step)						
Battery capacity (Ah)	150-500	250-500	400-800	500-1000	500-1000	125-250	250-500
Temperature sensor	√						
Can be used as power supply	√						
Remote alarm	Potential free contacts 60 V / 1 A (1x NO and 1x NC)						
Forced cooling	√						
Protection (1)	a,b,c,d						
Operating temp. range	-40 to +50°C (-40 - 122°F)						
Humidity (non condensing)	max 95%						
ENCLOSURE							
Material & Colour	aluminium (blue RAL 5012)						
Battery-connection	M8 studs						
230 V AC-connection	screw-clamp 2,5 mm ² (AWG 6)						
Protection category	IP 21						
Weight kg (lbs)	5,5 (12.1)	13 (28)	10 (22)	10 (22)	23 (48)	5,5 (12.1)	10 (12.1)
Dimensions hxxwx d in mm (hxxwx d in inches)	365x250x147 (14.4x9.9x5.8)	365x250x257 (14.4x9.9x10.1)	365x250x257 (14.4x9.9x10.1)	365x250x257 (14.4x9.9x10.1)	515x260x265 (20x10.2x10.4)	365x250x147 (14.4x9.9x5.8)	365x250x257 (14.4x9.9x10.1)
STANDARDS							
Safety	EN 60335-1, EN 60335-2-29						
Emission	EN 55014-1, EN 61000-3-2						
Immunity	EN 55014-2, EN 61000-3-3						
1) Protection	c. Battery voltage too high d. Temperature too high						
a. Output short circuit b. Battery reverse polarity detection							
2) Up to 40°C (100°F) ambient							



BMV-700 Battery Monitor

The BMV-700 Battery Monitor features an advanced microprocessor control system combined with high resolution measuring systems for battery voltage and charge/discharge current. Besides this, the software includes complex calculation algorithms, like Peukert's formula, to exactly determine the state of charge of the battery. The BMV-700 selectively displays battery voltage, current, consumed Ah or time to go.



Skylia Control

The Skylia Control allows you to alter the charge current and see the system status. Altering the charge current is useful if the shore power fuse is limited: the AC current drawn by the battery charger can be controlled by limiting the maximum output current, thereby preventing the shore power fuse from blowing.

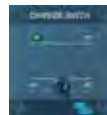

Charger Switch

A remote on-off switch



Battery Alarm

An excessively high or low battery voltage is indicated by an audible and visual alarm.

Orion DC/DC converters



Orion 24/12-5



Orion 24/12-17

Remote on-off connector on the high power models (see table below)

The remote on-off eliminates the need for a high current switch in the input wiring. The remote on-off can be operated with a low power switch or by the engine run/stop switch (see manual).

All models with adjustable output can also be used as a battery charger

For example to charge a 12 Volt starter or accessory battery in an otherwise 24 V system.

All models with adjustable output can be paralleled to increase output current

Up to five units can be connected in parallel.

The Orion 12/27,6-12: a 24 V battery charger (see page 2)

To charge a 24 V battery from a 12 V system.

The output voltage of this model can be adjusted with a potentiometer

A super wide input range buck-boost regulator: the Orion 7-35/12-3 (see page 2)

The Orion 7-35/12-3 is an isolated converter with a very wide input range, suitable for both 12 V and 24 V systems, and a fixed 12,6 V output.

Easy to install

Delivery includes four Insulated Fastons Female Crimp 6.3 mm (eight Fastons in case of the Orion 24/12-40).



Orion 24/12-25



Orion 24/12-40



Orion 24/12-70

Non isolated converters	Orion 24/12-5	Orion 24/12-12	Orion 24/12-17	Orion 24/12-25	Orion 24/12-40	Orion 24/12-70	Orion 12/24-8	Orion 12/24-10	Orion 12/24-20
Input voltage range (V)	18-35	18-35	18-35	18-35	18-35	18-35	9-18	9-18	9-18
Under voltage shutdown (V)	-	14	14	14	14	14	8	8	8
Under voltage restart (V)	-	18	18	18	18	18	10	10	10
Output voltage adjustable with potentiometer	no	no	no	yes	no	yes	no	yes	yes
Output voltage (V)	12	12	12	Adjustable 10-15 V F set 13,2 V	12	Adjustable 10-15 V F set 13,2 V	24	Adjustable 20-30 V F set 26,4 V	Adjustable 20-30 V F set 26,4 V
Efficiency (%)	92	95	94	96	95	92	95	95	93
Suitable to buffer-charge a battery	no	no	no	yes	no	yes	no	yes	yes
Can be connected in parallel	no	no	no	yes	no	yes	no	yes	yes
Continuous output current (A)	5	12	17	25	40	70	8	10	20
Max. Output current (A)	5	20	25	35	55	85	20	20	30
Fan assisted cooling (temp. controlled)	no	no	no	no	yes	yes	no	no	yes
Galvanic isolation	no	no	no	no	no	no	no	no	no
Off load current	< 5mA	< 7mA	< 7mA	< 15mA	< 20mA	< 20mA	< 10mA	< 15mA	< 30mA
Remote on-off	no	no	no	yes	yes	yes	no	no	yes
Operating temperature range (derate 3% per °C above 40°C)	-20 to +55°C	-20 to +55°C	-20 to +55°C	-20 to +55°C	-20 to +55°C	-20 to +55°C	-20 to +55°C	-20 to +55°C	-20 to +55°C
DC connection	Faston tabs 6.3 mm	Faston tabs 6.3 mm	Faston tabs 6.3 mm	Faston tabs 6.3 mm	Double Faston tabs 6.3 mm	M6 bolts	Faston tabs 6.3 mm	Faston tabs 6.3 mm	M6 bolts
Weight kg (lbs)	0,2 (0.40)	0,3 (0.65)	0,3 (0.65)	0,7 (1.55)	0,85 (1.9)	0,9 (2.0)	0,4 (0.8)	0,4 (0.9)	0,9 (2.0)
Dimensions hxxwx d in mm (hxxwx d in inches)	45x90x65 (1.8x3.5x2.6)	45x90x100 (1.8x3.5x3.9)	45x90x110 (1.8x3.5x3.9)	65x88x160 (2.6x3.5x6.3)	65x88x185 (2.6x3.5x7.3)	65x88x195 (2.6x3.5x7.7)	45x90x115 (1.8x3.5x4.5)	45x90x125 (1.8x3.5x4.5)	65x88x195 (2.6x3.5x7.7)
Standards: Safety Emission Immunity Automotive Directive	EN 60950 EN 61000-6-3, EN 55014-1 EN 61000-6-2, EN 61000-6-1, EN 55014-2 EN 50498								

Isolated Converters	Orion xx/yy-100W	Orion xx/yy-200W	Orion xx/yy-360W
Power rating (W)	100 (12,5 V / 8 A or 24 V / 4 A)	200 (12,5 V / 16 A or 24 V / 8 A)	360 (12,5 V / 30 A or 24 V / 15 A)
Galvanic isolation	yes	yes	yes
Temperature increase after 30 minutes at full load (°C)	25	30	30
Fan assisted cooling (temp. controlled)	no	yes	yes
Weight kg (lbs)	0,5 (1.1)	0,6 (1.3)	1,4 (3.1)
Dimensions hwxwd in mm (hwxwd in inches)	50 x 88 x 151 (1.9 x 3.5 x 6.0)	50 x 88 x 176 (1.9 x 3.5 x 7.2)	82 x 132 x 190 (3.2 x 5.2 x 7.5)
Input voltage (xx): 12 V (9 – 18 V) or 24 V (20 – 35 V) or 48 V (30 – 60 V) or 110V (60 – 140V)			
Output voltage (yy): 12,5 V, 24 V or 48V			

Isolated 24 V battery charger: Orion 12/27,6-12
 Input 9 – 18 V, output 27,6 V, current limit 12 A, fan assisted cooling
 Output voltage adjustable with potentiometer
 Weight 1,4 kg (3.1 lbs), dimensions 64 x 163 x 160 mm (2.5 x 6.4 x 6.3 inch)

Isolated buck-boost regulator: Orion 7-35/12-3
 Input 7 – 35 V, output 12,6 V current limit 3 A, derate current linearly from 3 A at 18 V to 1,5 A at 7 V
 Weight 1,4 kg (3.1 lbs), dimensions 64 x 163 x 160 mm (2.5 x 6.4 x 6.3 inch)

Common Characteristics	
Output voltage stability	2% (Orion 12/24-7 and Orion 12/24-10: + 0% / - 5%)
Output voltage tolerance	3%
Output noise	< 50 mV rms
Off load current	< 25 mA (isolated converters)
Efficiency	Non-isolated: appr. 92% Isolated: appr. 85%
Isolation	> 400 Vrms between input, output and case (isolated products only)
Operating temperature	- 20 to + 40°C (0 to 100°F). Derate linearly to 0 A at 70°C (160°F)
Humidity	Max 95% non-condensing
Casework	Anodised aluminium
Connections	6.3 mm (2.5 inch) push-on flat blade connectors
Protection: Overcurrent Overheating Reverse polarity connection Overvoltage	Short circuit proof Reduction of output voltage Fuse and reverse connected diode across input Varistor (also protects against load dump)
Standards: Safety Emission Immunity Automotive Directive	EN 60950 EN 61000-6-3, EN 55014-1 EN 61000-6-2, EN 61000-6-1, EN 55014-2 EN 50498



Orion isolated 100W



Orion isolated 360W

Orion IP67 24/12 DC-DC converter



Orion IP67 24/12-10
Orion IP67 24/12-20

Completely encapsulated: waterproof, shockproof and ignition protected

Water, oil or dirt will not damage the Orion IP67 DC-DC Converter. The casing is made of cast aluminium and the electronics are moulded in resin.

Extra-long input and output cables

Thanks to the cables of 1.8 meters in length, intermediate cable interconnections to increase length even more will in most cases not be needed. This is an important reliability increasing feature in an area where IP67 protection grade is needed.

Wide input voltage range

With 15 to 40 Volts input range, a stable output is ensured during surges or sags due to other equipment connected to same battery.

Protected against overheating

It can be used in a hot environment such as a machine room.



Orion IP67 24/12-5
with 1,8 m cables

Orion IP67	24/12-5	24/12-10	24/12-20
Input voltage range	15-40 VDC		
Under voltage shutdown	13 V		
Under voltage restart	14 V		
No load current at 24 V	1 mA	20 mA	50 mA
DC output voltage	12 V +/- 3%	12 V +/- 3%	12 V +/- 3%
Maximum continuous output current	5 A	10 A	20 A
Efficiency	93%	93%	95%
Ripple & Noise	75 mV pp		
Operating temperature range (derate 3% per °C above 40°C)	-20 to +70°C (full rated output up to 40°C)		
Overload protection	Hiccup mode, recovers automatically after fault condition is removed		
Short circuit proof	Yes		
Protection against reverse polarity connection	With external fuse or circuit breaker (not included)		
ENCLOSURE			
Material & Colour	Aluminium (blue RAL 5012)		
Protection category	IP67		
DC connection	Two input and two output cables, length 1,8 m		
Cable cross section, input	0,8 mm ² (18 AWG)	1,5 mm ² (15 AWG)	1,5 mm ² (15 AWG)
Cable cross section, output	0,8 mm ² (18 AWG)	1,5 mm ² (15 AWG)	2,6 mm ² (13 AWG)
Weight (kg)	50 g	300 g	300 g
Dimensions (h x w x d in mm)	25 x 43 x 20 mm	74 x 74 x 32 mm	74 x 74 x 32 mm
STANDARDS			
Safety	EN 60950		
Emission Immunity	EN 61000-6-3, EN 55014-1		
Automotive Directive	EN 55014-2, EN 61000-6-1, EN 61000-6-2		
Vibration	IEC 68-2-6: 10-150 Hz / 1.0 G		



Blue Power Panel GX



Blue Power Panel 2

Blue Power Panel

The Blue Power Panel provides intuitive control for all devices connected to the VE.Net network. It can be used to view and configure the full range of settings on VE.Net devices. Furthermore, its fully customizable overview screens make it the ideal monitoring tool for your power system.

The BPP now features an integrated VE.Net to VE.Bus Converter (VVC). This allows you to combine the powerful control of the VE Configure software with the simple interface of the BPP, without requiring a computer or additional interface devices.

BPP2 and BPP GX

The Blue Power Panel 2 and the Blue Power Panel GX almost have the same features. The difference between the two models is the design and the mounting of the panel. The body of the GX panel is made of plastic, which makes the panel lighter and adds a modern look to the panel. An extra advantage of the GX panel is the easy mounting: the included mounting frame allows the user to install the panel from either front or back side. Due to the mounting frame, the mounting holes will no longer be visible.

Features

- Full control & monitoring of all connected VE.Net devices
- Integrated VE.Net to VE.Bus Converter (VVC)
- Real-time system status read-outs
- Customizable overview screens
- Special mounting frame for front or back side mounting (only GX-model)
- Easy to install

	Blue Power Panel GX	Blue Power Panel 2
Power supply voltage range	9 – 70V DC	
Current draw @ 12V (VVC disabled)		
Standby	<1mA	
Backlight off	55mA	
Backlight on	70mA	
Current draw @ 12V (VVC enabled)		
Standby	<1mA	
Backlight off	70mA	
Backlight on	85mA	
Operating temp. range	-20 – +50°C	
Potential free contact	3A / 30VDC / 250V AC (Normally Open)	
ENCLOSURE		
Material & Colour	plastic	aluminium
Measurements front panel (w x h)	120 x 130mm (Standard PROS2 Panel)	
Measurements body (w x h)	100 x 110mm	
Weight	0.28Kg	

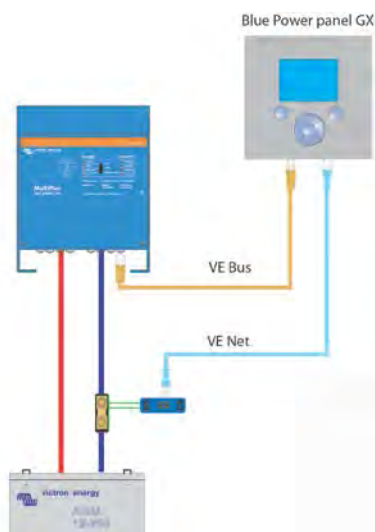

Color Control GX

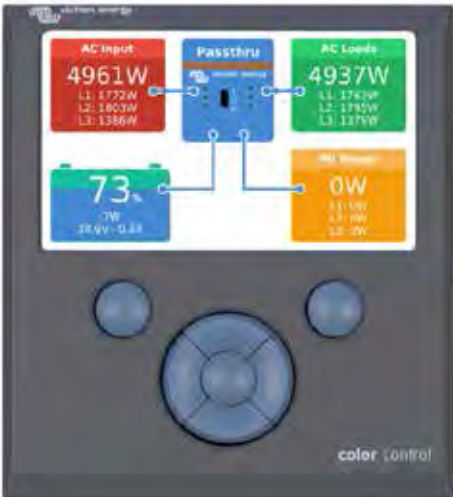

Color Control GX

The Color Control (CCGX) provides intuitive control and monitoring for all products connected to it. The list of Victron products that can be connected is endless: Inverters, Multis, Quattros, all our latest MPPT solar chargers, BMV-700, BMV-600, Lynx Ion + Shunt and more.

VRM Online Portal

Besides monitoring and controlling products on the CCGX, the information is also forwarded to our free remote monitoring website: the VRM Online Portal. To get an impression of the VRM Online Portal, visit <https://vrm.victronenergy.com>, and try our demo. See also the screenshots further down in this datasheet.

Future functionality

The CCGX has endless possibilities. To implement all our ideas and wishes will take years. There are therefore many features that are not yet available. Functions marked with 'Future function' will become available later on, as a firmware update. Firmware updates are free of charge, as with all updates of Victron products. Updating the product is easy: the CCGX will update itself automatically, as long as it is connected to the internet. Manual updates can be done with a USB stick and microSD cards.

Supported products

- Multis and Quattros, including split-phase and three-phase systems. Monitoring and control (on/off and current limiter). Changing settings is not yet available.
- BlueSolar MPPT 150/70 and the MPPT 150/85. Current solar output is visible on the overview screen, and all parameters are logged to the VRM online portal. Note that the VRM App has a nice overview showing data of the BlueSolar MPPT 150/70 as well. When multiple BlueSolar MPPTs with VE.Can are used in parallel, the Color Control will show all information as one. See also our blog-post about [synchronizing multiple MPPT 150/70 solar chargers](#).
- BlueSolar MPPT Solar Chargers with a VE.Direct port (70/15, 75/15, 100/15, 100/30, 75/50, 100/50, 150/35) can be connected to the VE.Direct ports on the CCGX. Connecting multiple at the same time is possible. They will all appear as a separate Solar Charger in the device list.
- BMV-700 family can be connected directly to the VE.Direct ports on the CCGX. Use the VE.Direct Cable for this. [See our pricelist](#).
- BMV-600 family can be connected to the VE.Direct ports on the CCGX. Use the VE.Direct to BMV60xS cable for that. [See our pricelist](#).
- Lynx Ion + Shunt
- Lynx Shunt VE.Can
- Skylla-i
- NMEA2000 tank sensors
- A USB GPS can be connected to the USB port. Location and speed will be visible on the display, and the data is sent to the VRM Portal for tracking purposes. The map on VRM will show the latest position.
- WiFi USB. [See our pricelist](#).

Note that there are more options for products which use the VE.Direct ports, such as BMVs and small MPPTs. They can also be connected through USB, useful when more than two products need to be connected. Use an off-the-shelf USB-hub and the VE.Direct to USB interface, ASS030530000.

Other highlights

- When connected to the internet, the CCGX will update itself automatically when there is a new software version available.
- Multiple languages: English, Chinese, German, Italian, Spanish, French, Swedish and Dutch.
- Use the CCGX as a Modbus-TCP gateway to all connected Victron products. See our [Modbus-TCP FAQ](#) for more information.

Notes for existing VGR2 and VER users

- Opposite to the Victron Global Remote 2 (VGR2) and Victron Ethernet Remote (VER), the CCGX stores all data locally during network interruptions. As soon as the connection to the VRM Online Portal is restored, it will automatically send all backlogged data to the portal. Data can then be analysed on <https://vrm.victronenergy.com>.
- The local website, as present on the VER, is not yet supported.
- The CCGX has no internal GPRS modem: you cannot insert a sim-card into the CCGX. Use an off-the-shelf GPRS or 3G router instead. See the [blog post about 3G routers](#).

More information

For help with installation please read the [Color Control GX Manual](#) and visit the [Frequently Asked Questions page](#).

Color Control GX			
Power supply voltage range	9 – 70V DC		
Current draw	12V DC	24V DC	48V DC
Switched off	0mA	0mA	0mA
Display off	140mA	80mA	40mA
Display at minimum intensity	160mA	90mA	45mA
Display at maximum intensity	245mA	125mA	65mA
Potential free contact	3A / 30V DC / 250V AC (Normally open)		
Communication ports			
VE.Direct	2 separate VE.Direct ports – isolated		
VE.Can	2 paralleled RJ45 sockets – isolated		
VE.Bus	2 paralleled RJ45 sockets – isolated		
USB	2 USB Host ports – not isolated		
Ethernet	10/100/1000MB RJ45 socket – isolated except shield		
3rd party interfacing			
Modbus-TCP	Use Modbus-TCP to monitor and control all products connected to the Color Control GX		
JSON	Use the VRM JSON API to retrieve data from the VRM Portal		
Other			
Outer dimensions (h x w x d)	130 x 120 x 28mm		
Operating temperature range	-20 to +50°C		

Overview - Multi with PV Inverter on output (Hub-2)



Overview - Multi

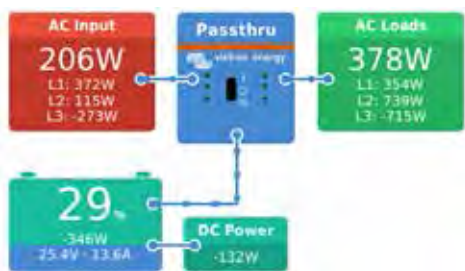

Overview - Multi with MPPT 150/70

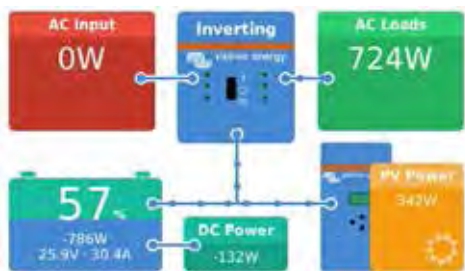

Main menu

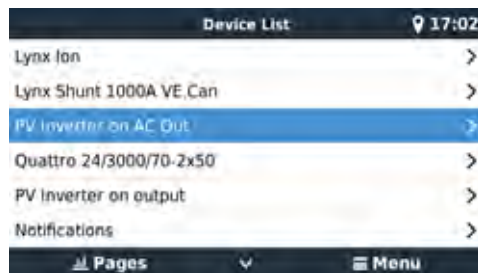

Alarm notifications

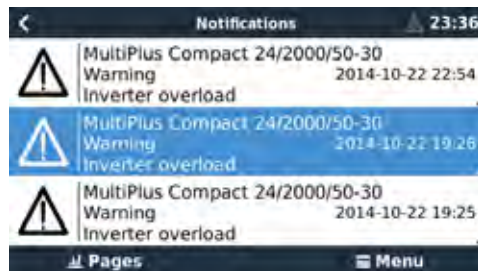

Tiles overview – Hub-2 system



VRM Portal – Live feed

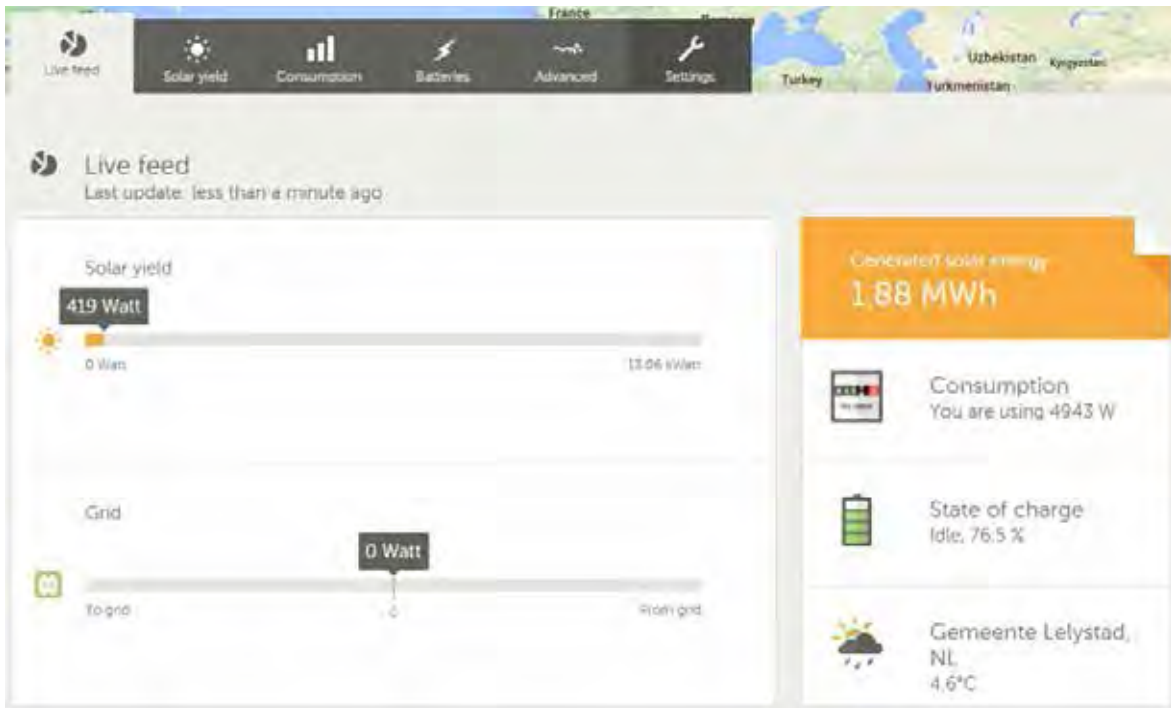

VRM Portal – Consumption

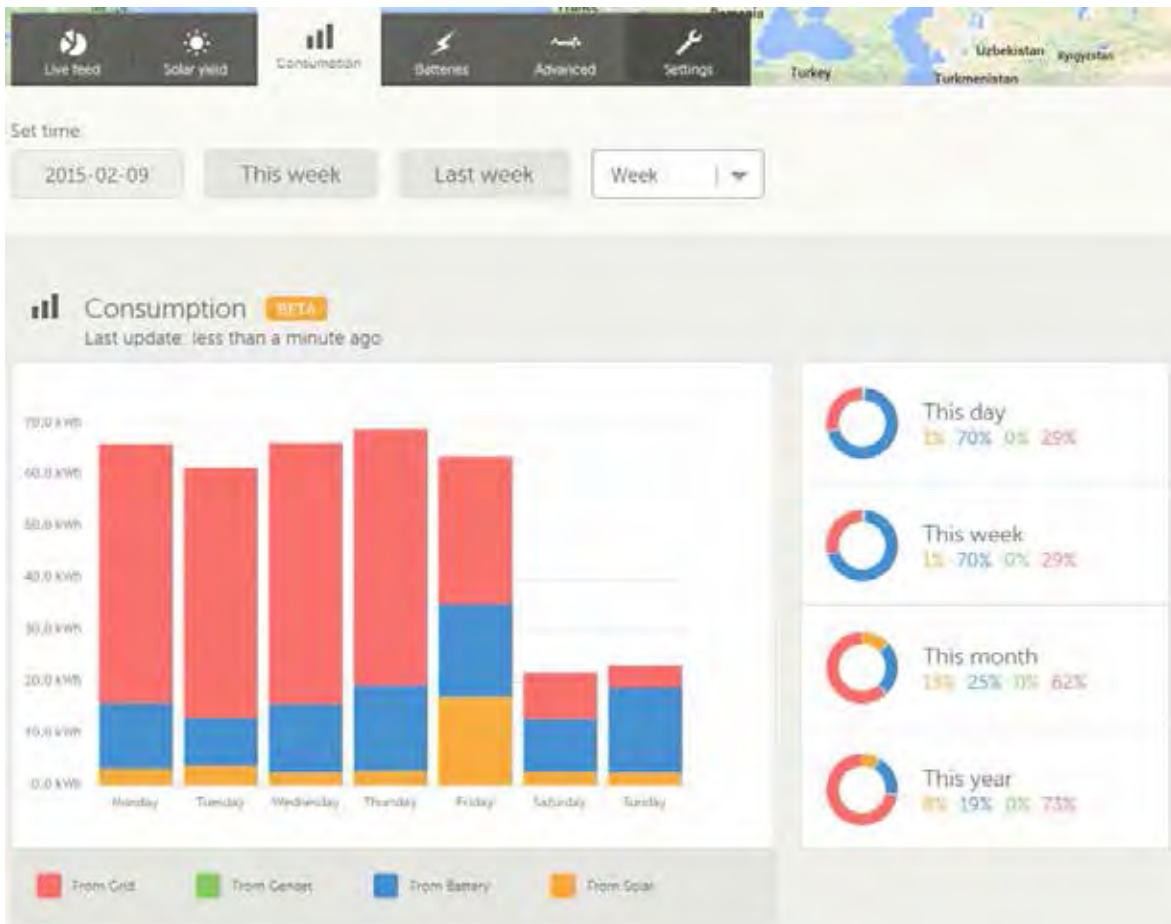

Color Control GX schematic diagram

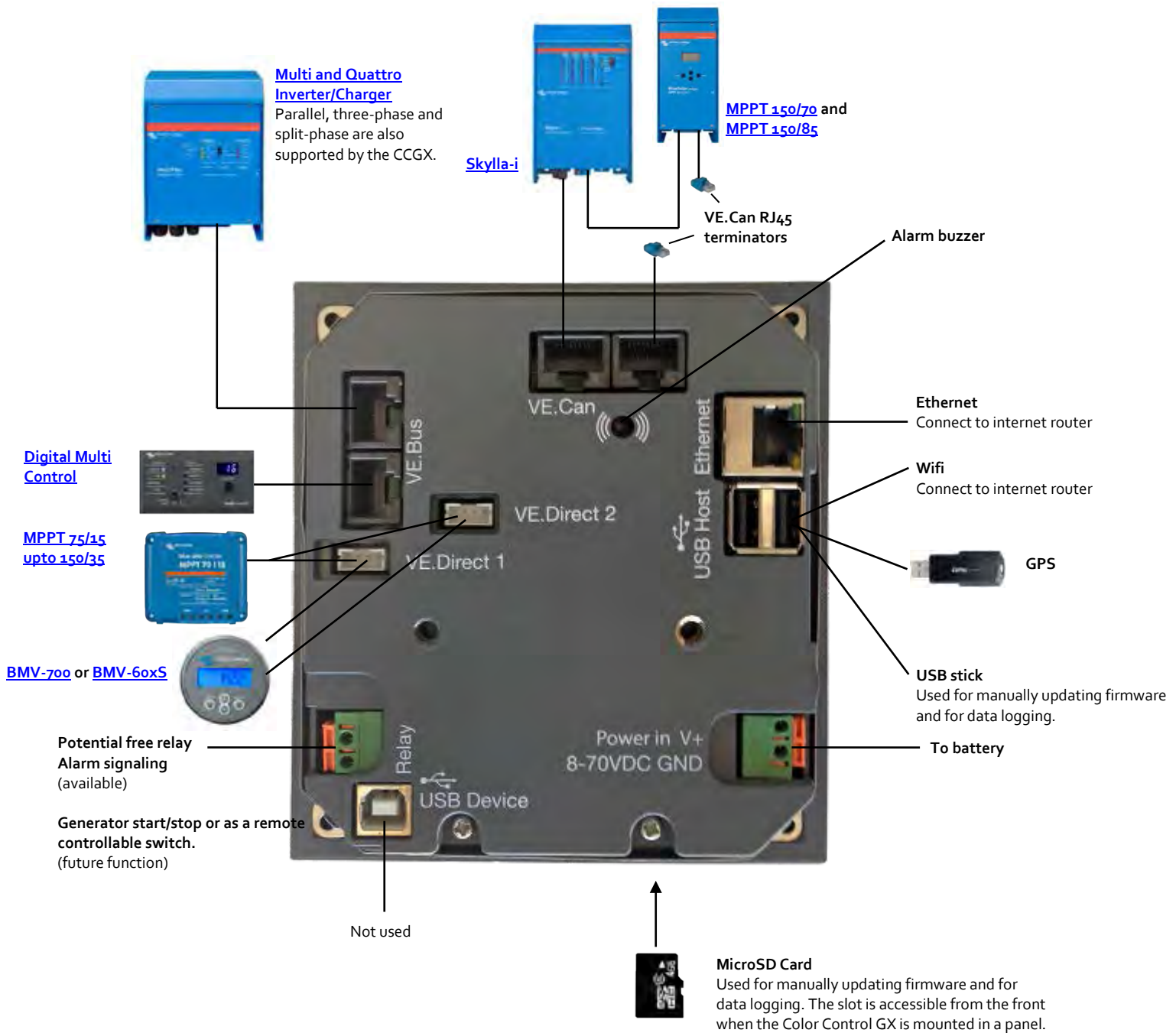

Cyrix-ct 12/24 V 120 A and 230 A



Cyrix-ct 12/24-120



LED status indicator

Cyrix-ct 12/24-230



Control cable for
Cyrix-ct 12/24-230
Length: 1 m

Intelligent battery monitoring to prevent unwanted switching

Some battery combiners (also called voltage controlled relay, or split charge relay) will disconnect a battery in case of a short but high amperage load. A battery combiner also may fail to connect a large but discharged battery bank because the DC voltage immediately drops below the disengage value once the batteries are connected. The software of the Cyrix-ct 12/24 does more than simply connect and disconnect based on battery voltage and with a fixed time delay. The Cyrix-ct 12/24 looks at the general trend (voltage increasing or decreasing) and reverses a previous action only if the trend has reversed during a certain period of time. The time delay depends on the voltage deviation from the trend.

(for Battery Combiners with multiple engage/disengage profiles, please see the Cyrix-i 4,00)

Long bolts to allow connection of more than one power cable

Cyrix 12/24-120: 13 mm (M6)

Cyrix 12/24-230: 16 mm (M8)

Protection against overheating (due to a long duration overload e.g.)

The Cyrix will disengage in case of excessive contact temperature, and reengage again after it has cooled down.

LED status indication (Cyrix 12/24 230 only)

LED on: engaged

LED 10 s flash: disengaged

LED 2 s flash: connecting

LED 2 s blink: disconnecting

LED 0,25 s blink: alarm (over temperature; voltage > 16 V; both batteries < 10 V; one battery < 2 V)

(multiply by two for 24 V)

12/24 V auto ranging

The Cyrix-ct 12/24 automatically detects system voltage.

No voltage loss

Cyrix battery combiners are an excellent replacement for diode isolators. The main feature is that there is virtually no voltage loss so that the output voltage of alternators or battery chargers does not need to be increased.

Prioritising the starter battery

In a typical setup the alternator is directly connected to the starter battery. The accessory battery, and possibly also a bow thruster and other batteries are each connected to the starter battery with Cyrix battery combiners. When a Cyrix senses that the starter battery has reached the connect voltage it will engage, to allow for parallel charging of the other batteries.

Bidirectional voltage sensing and power supply from both batteries

The Cyrix senses the voltage of both connected batteries. It will therefore also engage if for example the accessory battery is being charged by a battery charger.

The Cyrix-ct 12/24 has a dual power supply. It will therefore also close if the voltage on one battery is too low to operate the Cyrix.

In order to prevent unexpected operation during installation or when one battery has been disconnected, the Cyrix-ct 12/24 will not close if the voltage on one of the two battery connections is lower than 2 V (12 V battery) or 4 V (24 V battery).

Parallel connection in case of emergency (Start Assist)

The Cyrix can also be engaged with a push button (Cyrix remains engaged during 30 seconds) or a switch to connect batteries in parallel manually.

This is especially useful in case of emergency when the starter battery is discharged or damaged.

Cyrix Battery Combiner	Cyrix-ct 12/24-120	Cyrix-ct 12/24-230
LED status indication	No	Yes
Continuous current	120 A	230 A
Cranking rating (5 seconds)	180 A	500 A
Connect voltage	From 13 V to 13,8 V and 26 to 27,6 V with intelligent trend detection	
Disconnect voltage	From 11 V to 12,8 V and 22 to 25,7 V with intelligent trend detection	
Current consumption when open	<4 mA	
Current consumption when closed	12 V : 220 mA 24 V : 120 mA	12 V : 320 mA 24 V : 180 mA
Start Assist	Yes (Cyrix remains engaged during 30 seconds)	
Control cable included (length 1 m)	No	Yes
Protection category	IP54	
Weight kg (lbs)	0,11 (0.24)	0,27 (0.6)
Dimensions h x w x d in mm (h x w x d in inches)	46 x 46 x 80 (1.8 x 1.8 x 3.2)	65 x 100 x 50 (2.6 x 4.0 x 2.0)

Connect (V)	Delay
$V < 13 V$	Remains open
$13,0 V < V < 13,2 V$	10 min
$13,2 V < V < 13,4 V$	5 min
$13,4 V < V < 13,6 V$	1 min
$13,6 V < V < 13,8 V$	4 sec

Disconnect (V)	Delay
$V < 11 V$	0 sec
$11,0 V < V < 12,0 V$	1 sec
$12,0 V < V < 12,2 V$	10 sec
$12,2 V < V < 12,4 V$	30 sec
$12,4 V < V < 12,8 V$	3 min
$> 12,8 V$	remains closed
$> 16 V$	over voltage disconnect

Approximate connect and disconnect delay
(multiply by two for a 24 V system)

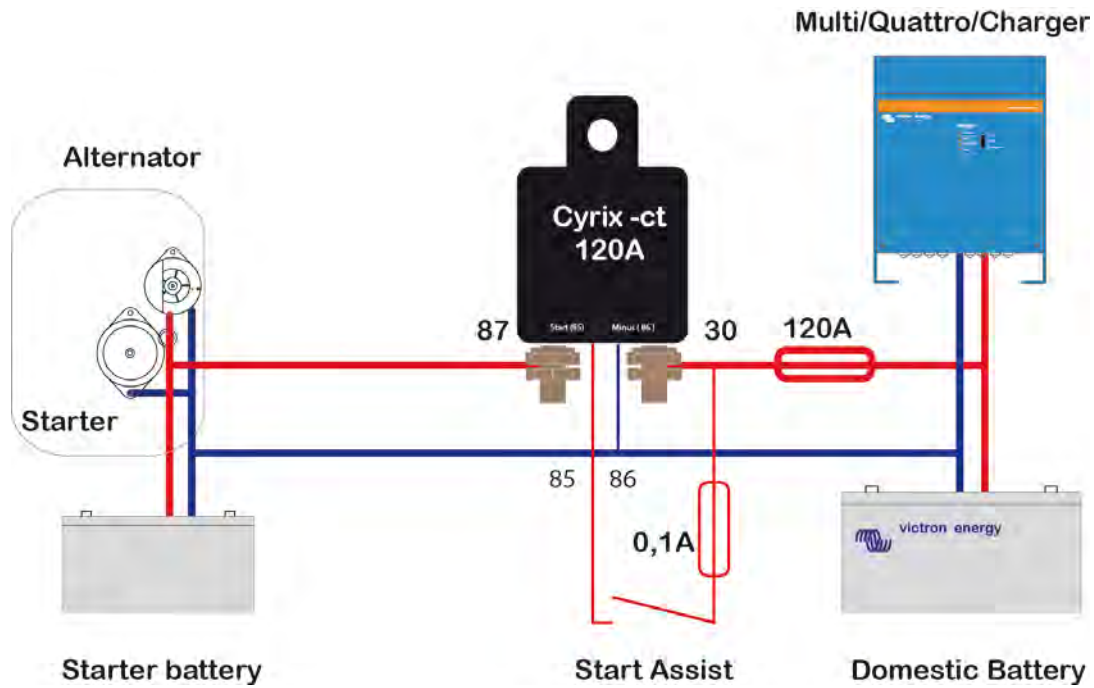

Cyrix-ct 12/24-120: connection diagram

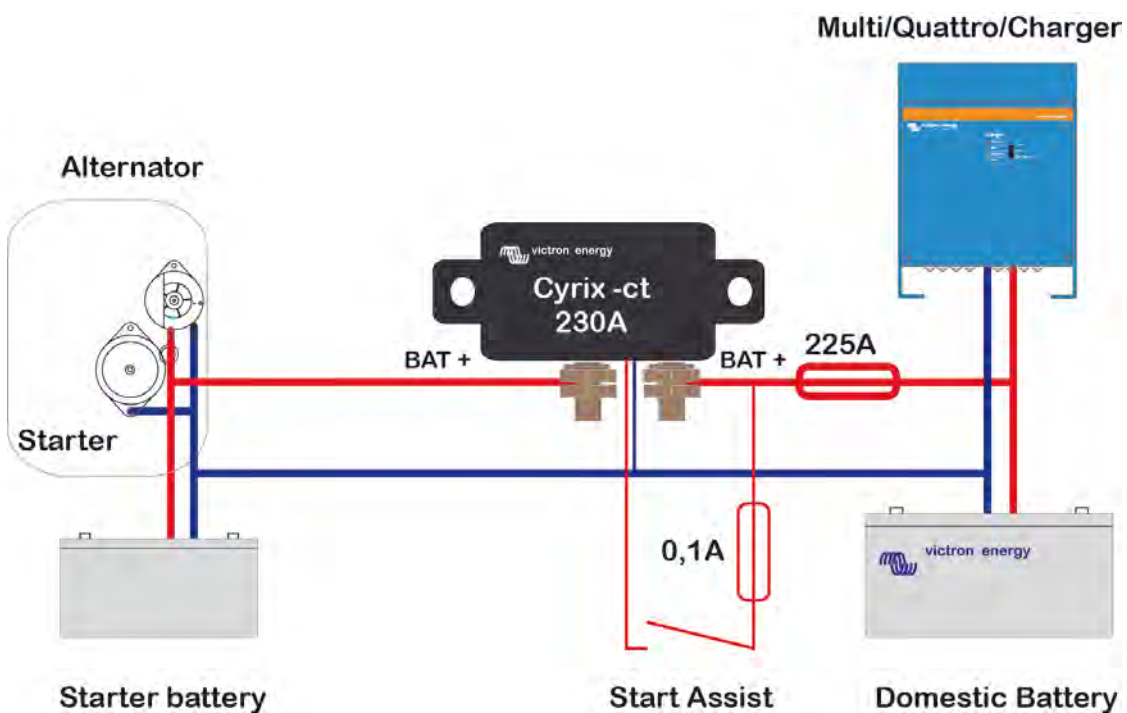

Cyrix-ct 12/24-230: connection diagram



Cyrix-i 24/48 V 400 A

New: intelligent battery monitoring to prevent unwanted switching

Some battery combiners will disconnect a battery in case of a short but high amperage load. A battery combiner also may fail to connect a large but discharged battery bank because the DC voltage immediately drops below the disengage value once the batteries are connected.

The software of the Cyrix-i does more than simply connect and disconnect based on battery voltage and with a fixed time delay. The Cyrix-i looks at the general trend (voltage increasing or decreasing) and reverses a previous action only if the trend has reversed during a certain period of time. The time delay depends on the voltage deviation from the trend.

In addition, four switch timing profiles can be chosen (see back page).

12/24 V and 24/48 V auto ranging

The Cyrix-i automatically detects system voltage.

No voltage loss

Cyrix battery combiners are an excellent replacement for diode isolators. The main feature is that there is virtually no voltage loss so that the output voltage of alternators or battery chargers does not need to be increased.

Prioritizing the starter battery

In a typical setup the alternator is directly connected to the starter battery. The accessory battery, and possibly also a bow thruster and other batteries are each connected to the starter battery with Cyrix battery combiners. When a Cyrix senses that the starter battery has reached the connect voltage it will engage, to allow for parallel charging of the other batteries.

Bidirectional voltage sensing and power supply from both batteries

The Cyrix senses the voltage of both connected batteries. It will therefore also engage if for example the accessory battery is being charged by a battery charger.

The Cyrix-i has a dual power supply. It will therefore also close if the voltage on one battery is too low to operate the Cyrix.

In order to prevent unexpected operation during installation or when one battery has been disconnected, the Cyrix-i will not close if the voltage on one of the two battery connections is lower than 2 V (12 V battery), or 4 V (24 V battery) or 8 V (48 V battery).

Parallel connection in case of emergency

The Cyrix can also be engaged with a push button (Cyrix remains engaged during 30 s) or a switch to connect batteries in parallel manually.

This is especially useful in case of emergency when the starter battery is discharged or damaged.

Model	Cyrix-i 12/24-400 Cyrix-i 24/48-400
Continuous current	400A
Peak current	2000A during 1 second
Input voltage 12/24 V model	8-36 VDC
Input voltage 24/48 V model	16-72 VDC
Connect/disconnect profiles	See table
Over voltage disconnect	16 V / 32 / 64 V
Current consumption when open	4 mA
Emergency start	Yes, 30 s
Micro switch for remote monitoring	Yes
Status indication	Bicolour LED
Weight kg (lbs)	0,9 (2.0)
Dimensions h x w x d in mm (h x w x d in inches)	78 x 102 x 110 (3.1 x 4.0 x 4.4)

Profile 0			
Connect (V)*		Disconnect (V)*	
Less than 13 V	Remains open	More than 12,8 V	Remains closed
	Closes after		Opens after
13 V	10 min	12,8 V	10 min
13,2 V	5 min	12,4 V	5 min
13,4 V	3 min	12,2 V	1 min
13,6 V	1 min	12 V	4 sec
13,8 V	4 sec	Less than 11 V	Immediate

Profile 1			
Connect (V)*		Disconnect (V)*	
Less than 13,25 V	Remains open	More than 12,75 V	Remains closed
More than 13,25 V	Closes after 30 sec	From 10,5 V to 12,75 V	Opens after 2 min
		Less than 10,5 V	Immediate

Profile 2			
Connect (V)*		Disconnect (V)*	
Less than 13,2 V	Remains open	More than 12,8 V	Remains closed
More than 13,2 V	Closes after 6 sec	From 10,5 V to 12,8 V	Opens after 30 sec
		Less than 10,5 V	Immediate

Profile 3			
Connect (V)*		Disconnect (V)*	
Less than 13,25 V	Remains open	More than 13,5 V	Remains closed
	Closes after		Opens after
13 V	10 min	12,8 V	30 min
13,2 V	5 min	12,4 V	12 min
13,4 V	3 min	12,2 V	2 min
13,6 V	1 min	12 V	1 min
13,8 V	4 sec	Less than 10,5 V	Immediate

- NOTES**
- 1) After connecting 3 times, the minimum time to reconnect is 1 minute (to prevent 'rattling')
 - 2) The Cyrix will not connect if the voltage on one of the battery connections is less than 2 V*. (to prevent unexpected switching during installation)
 - 3) The Cyrix will always connect if the **start assist** is activated, as long as the voltage on one of the battery connections is sufficient to operate the Cyrix (approximately 10 V*)
- * Multiply voltage x2 for 24 V systems and x4 for 48 V systems

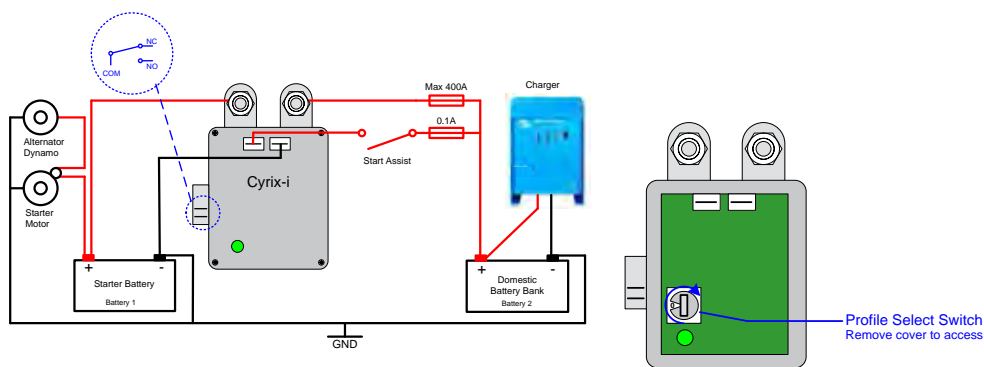

Victron Global Remote 2 and Victron Ethernet Remote



Victron Global Remote 2: A GSM/GPRS modem

The Global Remote is a modem which sends alarms, warnings and system status reports to cellular phones via text messages (SMS). It can also log data from Victron Battery Monitors, Multis, Quattros and Inverters to a website through a GPRS connection. The use of this website is free of charge.

Victron Ethernet Remote: A GSM/GPRS modem with Ethernet connection

The Ethernet Remote has the same functions as the Global Remote. An extra function of the Ethernet Remote is that it can connect with LAN, due to a special cable. In this way, the Ethernet Remote can be connected to the internet without a SIM-card.



Victron Global Remote 2

Simple and easy to use

The idea is simple: you can use it to get SMS alarms from a Multi, a Battery System, or both. When monitoring the usage of batteries, it can be extremely helpful to receive under- and overvoltage alarms; whenever they occur. For this purpose, the Global Remote is perfect. A prepaid SIM-card (for example) in combination with the Global Remote is adequate for remotely monitoring your system.

Connections Global Remote

The Global Remote has two serial connections. They can be used to connect to a VE.Bus Multi/Quattro/Inverter unit or system. This connection needs a MK2 which is supplied with the VGR. The other connection is to connect a BMV-600S or BMV-602S Battery Monitor. To connect it to a BMV you will also need the connection kit accessory which needs to be purchased separately. The Global Remote also has a connection for an optional accessory, the VGR IO Extender.



Victron Ethernet Remote

Connections Ethernet Remote

The Ethernet Remote has one serial connection. This can be used to connect to a VE.Bus Multi/Quattro/Inverter unit or system, or a BMV Battery Monitor. To connect it to a BMV you will also need the connection kit accessory which needs to be purchased separately.

Advanced use: Monitoring historic data

Taking it one step further, an internet browser and -connection is all you need to view all of the data online. You can simply create an account on the website and add your modem(s). Subsequently you can configure the GPRS connection, which will enable you to monitor the historic data of several basic properties such as system voltages, power levels and status information. All of this data is graphed. These graphs are available in daily, weekly and monthly timeframes.

VRM Online Portal

The information from the VGR and VER is forwarded to our free remote monitoring website: the VRM Online Portal. To get an impression of the VRM Online Portal, visit <https://vrm.victronenergy.com/>, and try our demo. The portal is free of charge.

Victron Global Remote

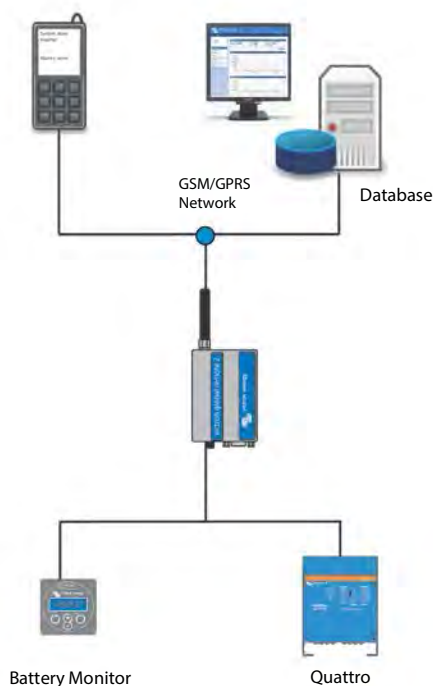

Victron Ethernet Remote

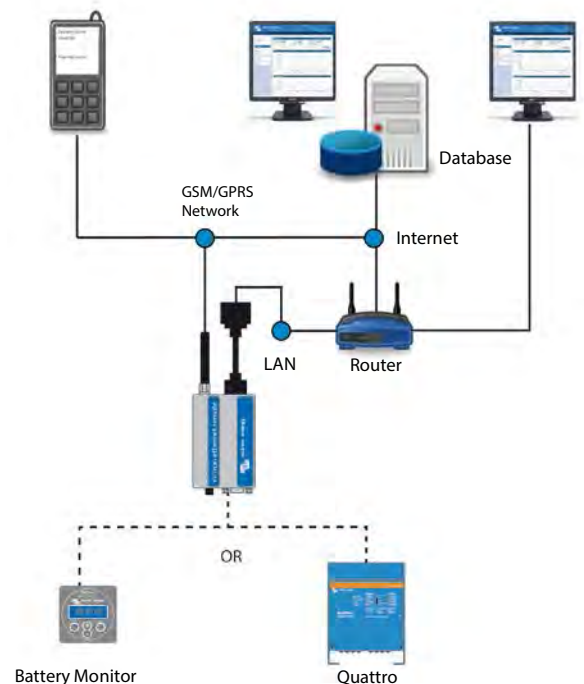

	Victron Global Remote 2	Victron Ethernet Remote
Serial connection (Mk2.2a – included)	Connect VE.Bus Multi/Quattro/Inverter unit/system	
Serial connection (BMV-602 Datalink – not included)	Connect BMV-602 Battery Monitor	
	GENERAL	
Power supply voltage range	5.5 to 32 VDC	
Current draw (max.)	0.48 A at 5.5 VDC	
Current draw (connected to GSM network)	90mA at 12 VDC and 50 mA at 24 VDC	
Operating temperature range	-30°C to 75°C / -22° to 167°F	
	ENCLOSURE	
Dimensions VGR Modem (hwxwd)	73 x 54.5 x 25.5 mm / 2.9 x 2.1 x 1 inch	
Weight VGR Modem	89 grams / 3.1 ounces	
Body	Aluminium	
Installation	Two aluminium mounting bridles	
	GSM / GPRS	
GPRS data usage	Depends on usage	
Antenna connection	50 Ohm SMA	
	INCLUDED ACCESSORIES	
GSM antenna	Included	Included
Ethernet attachment	n.a.	Included
Battery cable	With inline fuse	Included
Y-cable for serial and IO Extender connection	Included	Included
Male DB15 to female DB9 cable	Included	Included
MK2 interface	Included	Included
	OPTIONAL ACCESSORIES (NOT INCLUDED, TO BE ORDERED SEPARATELY)	
Global Remote to BMV-60xS conn. kit	Compatible	Compatible
VGR IO Extender	Compatible	Not compatible
Global Remote Antenna	Compatible	Compatible



BMV-700

The BMV-700 is our newest high precision battery monitors. The essential function of a battery monitor is to calculate ampere-hours consumed as well as the state of charge of a battery. Ampere-hours consumed are calculated by integrating the current flowing in or out of the battery.



Victron Global Remote to BMV-60xS conn. kit

Cable kit required to connect the BMV-60xS and the Victron Global Remote. BMV 60xS Data Link included.



MultiPlus Inverter/Charger

The MultiPlus is a powerful true sine wave inverter, a sophisticated battery charger that features adaptive charge technology, and a high-speed AC transfer switch in a single compact enclosure.



Phoenix Inverter

Pure sine wave output, high peak power and high efficiency. Combined high frequency and line frequency technologies ensure the best of both worlds.



Quattro Inverter/Charger

The Quattro can be connected to two independent AC sources, for example shore-side power and a generator, or two generators. The Quattro will automatically connect to the active source.



Global Remote Antenna

The Global Remote Antenna is an optional accessory to improve the reception of the Victron Global Remote. The Global Remote Antenna replaces the standard antenna that is included with the Global Remote. The antenna is an outdoor 4dBi Gain antenna for stationary usage. A standard 5m low loss coax cable and wall-mount is included.

Specifications:

- Frequency: 900 (2dBi) / 1800 & 1900-1990 and 1990-2200 and 2400 MHz
- Vertically polarized
- Antenna length: 24 cm
- Antenna diameter: 1,8 cm
- Impedance: 50 Ω
- Connector: SMA-M connector

Example of graph available on <https://vrm.victronenergy.com>

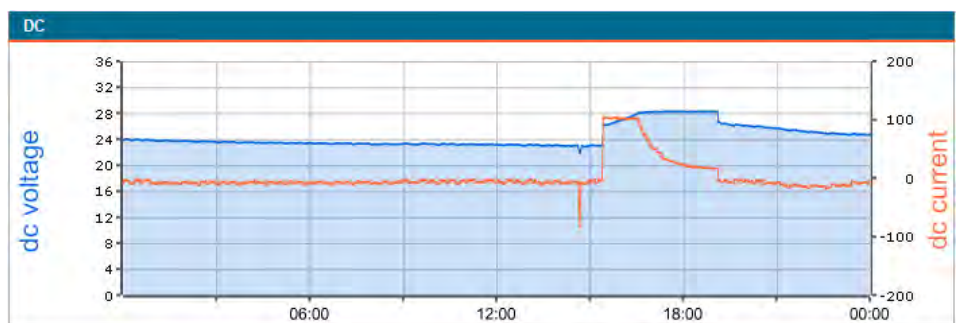

Note that it is not possible to combine the Global Remote or Ethernet Remote with one of the following products in a VE.Bus system:

- VE.Net to VE.Bus Converter
- Blue Power Panel 2
- Blue Power Panel GX
- VE.Bus to NMEA2000 interface

Combining with the Digital Multi Control, VE.Bus Multi Control or Phoenix Inverter Control is possible.

BMV 700 series: precision battery monitoring



BMV-700



BMV bezel square



BMV shunt 500A/50mV
With quick connect pcb



BMV-702 Black



BMV-700H

Battery 'fuel gauge', time-to-go indicator, and much more

The remaining battery capacity depends on the ampere-hours consumed, discharge current, temperature and the age of the battery. Complex software algorithms are needed to take all these variables into account.

Next to the basic display options, such as voltage, current and ampere-hours consumed, the BMV-700 series also displays state of charge, time to go, and power consumption in Watts.

The BMV-702 features an additional input which can be programmed to measure the voltage (of a second battery), battery temperature or midpoint voltage (see below).

Bluetooth Smart

Use the Bluetooth Smart dongle to monitor your batteries on Apple or Android smartphones, tablets, macbooks and other devices.

Easy to install

All electrical connections are to the quick connect PCB on the current shunt. The shunt connects to the monitor with a standard RJ12 telephone cable. Included: RJ 12 cable (10 m) and battery cable with fuse (2 m); no other components needed.

Also included are a separate front bezel for a square or round display appearance, a securing ring for the rear mounting and screws for the front mounting.

Easy to program (with your smartphone!)

A quick install menu and a detailed setup menu with scrolling texts assist the user when going through the various settings.

Alternatively, choose the fast and easy solution: download the smartphone app (Bluetooth Smart dongle needed)

Midpoint voltage monitoring (BMV-702 only)

This feature, which is often used in industry to monitor large and expensive battery banks, is now for the first time made available at a low cost, to monitor any battery bank.

A battery bank consists of a string of series connected cells. The midpoint voltage is the voltage halfway along the string. Ideally, the midpoint voltage would be exactly half of the total voltage. In practice, however, deviations will be seen, that depend on many factors such as a different state of charge for new batteries or cells, different temperatures, internal leakage currents, capacities and much more.

Large or increasing deviation of the midpoint voltage, points to improper battery care or a failed battery or cell. Corrective action following a midpoint voltage alarm can prevent severe damage to an expensive battery. Please consult the BMV manual for more information.

Standard features

- Battery voltage, current, power, ampere-hours consumed and state of charge
- Remaining time at the current rate of discharge
- Programmable visual and audible alarm
- Programmable relay, to turn off non critical loads or to run a generator when needed
- 500 Amp quick connect shunt and connection kit
- Shunt selection capability up to 10.000 Amps
- VE.Direct communication port
- Stores a wide range of historical events, which can be used to evaluate usage patterns and battery health
- Wide input voltage range: 9,5 – 95V
- High current measurement resolution: 10 mA (0,01A)
- Low current consumption: 2,9Ah per month (4mA) @12V and 2,2Ah per month (3mA) @ 24V

BMV-702 additional features

Additional input to measure voltage (of a second battery), temperature or midpoint voltage, and corresponding alarm and relay settings.

BMV-700HS: 60 to 385 VDC voltage range

No additional parts needed. Note: suitable for systems with grounded minus only (battery monitor is not isolated from shunt).

Other battery monitoring options

- VE.Net Battery Controller
- High voltage VE.Net Battery Controller: 70 to 350 VDC
- Lynx Shunt VE.Net
- Lynx Shunt VE.Can

More about midpoint voltage

One bad cell or one bad battery can destroy a large, expensive battery bank. When batteries are connected in series, a timely warning can be generated by measuring the midpoint voltage. Please see the BMV manual, section 5.2, for more information.

We recommend our [Battery Balancer](#) (BMS012201000) to maximize service life of series-connected batteries.

Battery Monitor	BMV-700	BMV-702 BMV-702 BLACK	BMV-700HS
Supply voltage range	6,5 - 95 VDC	6,5 - 95 VDC	60 - 385 VDC
Current draw, back light off	< 4mA	< 4mA	< 4mA
Input voltage range, auxiliary battery	n. a.	6,5 - 95 VDC	n. a.
Battery capacity (Ah)	20 - 9999 Ah		
Operating temperature range	-40 +50°C (-40 - 120°F)		
Measures voltage of second battery, or temperature, or midpoint	No	Yes	No
Temperature measurement range	-20 +50°C		n. a.
VE.Direct communication port	Yes	Yes	Yes
Relay	60V / 1A normally open (function can be inverted)		
RESOLUTION & ACCURACY (with a 500A shunt)			
Current	± 0,01A		
Voltage	± 0,01V		
Amp hours	± 0,1 Ah		
State of charge (0 - 100%)	± 0,1%		
Time to go	± 1 min		
Temperature (0 - 50°C or 30 - 120°F)	n. a.	± 1°C/°F	n. a.
Accuracy of current measurement	± 0,4%		
Accuracy of voltage measurement	± 0,3%		
INSTALLATION & DIMENSIONS			
Installation	Flush mount		
Front	63mm diameter		
Front bezel	69 x 69mm (2.7 x 2.7 inch)		
Body diameter	52mm (2.0 inch)		
Body depth	31mm (1.2 inch)		
STANDARDS			
Safety	EN 60335-1		
Emission / Immunity	EN 55014-1 / EN 55014-2		
Automotive	ECE R10-4 / EN 50498		
ACCESSORIES			
Shunt (included)	500A / 50mV		
Cables (included)	10 meter 6 core UTP with RJ12 connectors, and cable with fuse for '+' connection		
Temperature sensor	Optional (ASS00100000)		



Victron Global Remote

The Global Remote is a modem which sends alarms, warnings and system status reports to cellular phones via text messages (SMS). It can also log data from Victron Battery Monitors, MultiPlus units, Quattros and Inverters to a website through a GPRS connection to the [VRM Portal](#). Access to this website is free of charge. VE.Direct to Global remote interface cable needed (ASS030534000).



1000A/50mV, 2000A/50mV and 600A/50mV shunt

The quick connect PCB on the standard 500A/50mV shunt can also be mounted on these shunts.



Interface cables

- VE.Direct cables to connect a BMV 70x to the Color Control (ASS030530xxx)
- VE.Direct to USB interface (ASS030530000) to connect several BMV 70x to the Color Control or to a computer.
- VE.Direct to Global remote interface to connect a BMV 70x to a Global Remote. (ASS030534000)

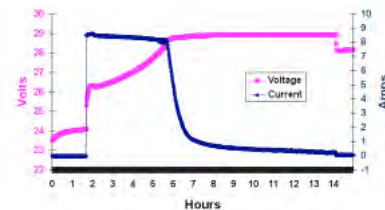

The PC application software **BMV-Reader** will show all current readings on a computer, including history data. It can also log the data to a CSV formatted file. It is available for free, and can be downloaded from our website at the [Support and downloads section](#). Connect the BMV to the computer with the VE.Direct to USB interface, ASS030530000.



Color Control

The powerful Linux computer, hidden behind the colour display and buttons, collects data from all Victron equipment and shows it on the display. Besides communicating with Victron equipment, the Color Control communicates through CAN bus (NMEA2000), Ethernet and USB. Data can be stored and analysed on the VRM Portal.



A maximum of four BMVs can be connected directly to the Color Control. Even more BMVs can be connected to a USB Hub for central monitoring.



Battery Balancer (BMS012201000)

The Battery Balancer equalizes the state of charge of two series connected 12V batteries, or of several parallel strings of series connected batteries.

When the charge voltage of a 24V battery system increases to more than 27V, the Battery Balancer will turn on and compare the voltage over the two series connected batteries. The Battery Balancer will draw a current of up to 1A from the battery (or parallel connected batteries) with the highest voltage. The resulting charge current differential will ensure that all batteries will converge to the same state of charge.

If needed, several balancers can be paralleled.

A 48V battery bank can be balanced with three Battery Balancers.



With the VE.Direct to Bluetooth Smart dongle real time data and alarms can be displayed on Apple and Android smartphones, tablets, macbooks and other devices.

Also use your smartphone to adjust settings!

(the VE.Direct to Bluetooth Smart dongle must be ordered separately)



See the [VictronConnect BMV app Discovery Sheet](#) for more screenshots

Argo diode battery isolators



**Argo Diode Isolator
120-2AC**



**Argo Diode Isolator
140-3AC**

Diode battery isolators allow simultaneous charging of two or more batteries from one alternator, without connecting the batteries together. Discharging the accessory battery for example will not result in also discharging the starter battery.

The Argo Battery Isolators feature a low voltage drop thanks to the use of Schottky diodes: at low current the voltage drop is approximately 0,3 V and at the rated output approximately 0,45 V. All models are fitted with a compensation diode that can be used to slightly increase the output voltage of the alternator. This compensates for the voltage drop over the diodes in the isolator.

Please see our book 'Energy Unlimited' or ask for specialist advice when installing a diode isolator. Simply inserting the isolator in the cabling between the alternator and the batteries will slightly reduce charge voltage. The result can be that batteries are not charged to the full 100% and age prematurely.

Alternator energize input

Some alternators need DC voltage on the B+ output to start charging. Obviously, DC will be present when the alternator is directly connected to a battery. Inserting a Diode or FET splitter will however prevent any return voltage/current from the batteries to the B+, and the alternator will not start.

The new 'AC' diode isolators feature a special current limited energize input that will power the B+ when the engine run/stop switch is closed.

Argo Diode Battery Isolator	80-2SC	80-2AC	100-3AC	120-2AC	140-3AC	160-2AC	180-3AC
Maximum charge current (A)	80	80	100	120	140	160	180
Maximum alternator current (A)	80	80	100	120	140	160	180
Number of batteries	2	2	3	2	3	2	3
Alternator Energize Input	no	yes	yes	yes	yes	yes	yes
Connection	M6 Studs	M6 Studs	M6 Studs	M8 Studs	M8 Studs	M8 Studs	M8 Studs
Compensation diode and Energize connection	6,3 mm Faston	6,3 mm Faston	6,3 mm Faston	6,3 mm Faston	6,3 mm Faston	6,3 mm Faston	6,3 mm Faston
Weight kg (lbs)	0,5 (1.3)	0,6 (1.3)	0,8 (1.8)	0,8 (1.8)	1,1 (2.5)	1,1 (2.5)	1,5 (3.3)
Dimensions h x w x d in mm (h x w x d in inches)	60 x 120 x 75 (2.4 x 4.7 x 3.0)	60 x 120 x 90 (2.4 x 4.7 x 3.9)	60 x 120 x 115 (2.4 x 4.7 x 4.5)	60 x 120 x 115 (2.4 x 4.7 x 4.5)	60 x 120 x 150 (2.4 x 4.7 x 5.9)	60 x 120 x 150 (2.4 x 4.7 x 5.9)	60 x 120 x 200 (2.4 x 4.7 x 7.9)

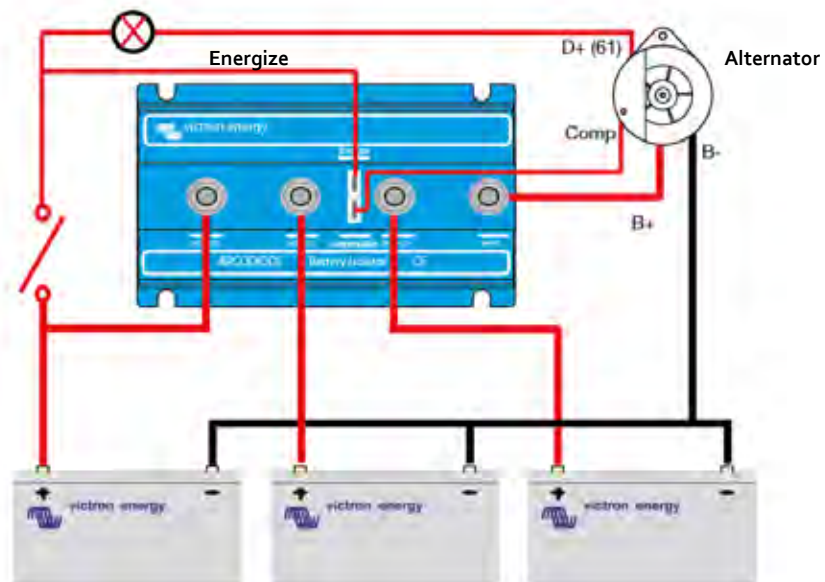



Argo FET 100-3
3bat 100A

Similarly to Diode Battery Isolators, FET Isolators allow simultaneous charging of two or more batteries from one alternator (or a single output battery charger), without connecting the batteries together. Discharging the accessory battery for example will not result in also discharging the starter battery.

In contrast with Diode Battery Isolators, FET Isolators have virtually no voltage loss. Voltage drop is less than 0,02 Volt at low current and averages 0,1 Volt at higher currents.

When using Argo FET Battery Isolators, there is no need to also increase the output voltage of the alternator. However, care should be taken to keep cable lengths short and of sufficient cross section.

Example:

When a current of 100 A flows through a cable of 50 mm² cross section (AWG 0) and 10 m length (30 ft), the voltage drop over the cable will be 0,26 Volt. Similarly a current of 50 A through a cable of 10 mm² cross section (AWG 7) and 5 m length (15 ft) will result in a voltage drop of 0,35 Volt!

Alternator energize input

Some alternators need DC voltage on the B+ output to start charging. Obviously, DC will be present when the alternator is directly connected to a battery. Inserting a Diode or FET splitter will however prevent any return voltage/current from the batteries to the B+, and the alternator will not start.

The new Argo FET Isolators have a special current limited energize input that will power the B+ when the engine run/stop switch is closed.



Argo FET 100-3
3bat 100A

Argo FET Battery Isolator	Argo FET 100-2	Argo FET 100-3	Argo FET 200-2	Argo FET 200-3
Maximum charge current (A)	100	100	200	200
Maximum alternator current (A)	100	100	200	200
Number of batteries	2	3	2	3
Connection	M8 bolts	M8 bolts	M8 bolts	M8 bolts
Weight kg (lbs)	1,4 (3.1)	1,4 (3.1)	1,4 (3.1)	1,4 (3.1)
Dimensions: h x w x d in mm (h x w x d in inches)	65 x 120 x 200 (2.6 x 4.7 x 7.9)	65 x 120 x 200 (2.6 x 4.7 x 7.9)	65 x 120 x 200 (2.6 x 4.7 x 7.9)	65 x 120 x 200 (2.6 x 4.7 x 7.9)

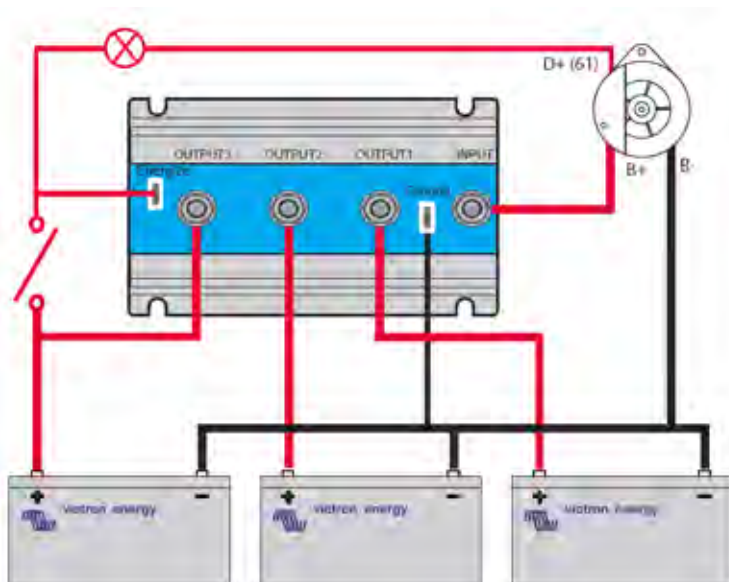

Battery Balancer

The problem: the service life of an expensive battery bank can be substantially shortened due to state of charge unbalance

One battery with a slightly higher internal leakage current in a 24V or 48V bank of several series/parallel connected batteries will cause undercharge of that battery and parallel connected batteries, and overcharge of the series connected batteries. Moreover, when new cells or batteries are connected in series, they should all have the same initial state of charge. Small differences will be ironed out during absorption or equalize charging, but large differences will result in damage due to excessive gassing (caused by overcharging) of the batteries with the higher initial state of charge and sulphation (caused by undercharging) of the batteries with the lower initial state of charge.

The Solution: battery balancing

The Battery Balancer equalizes the state of charge of two series connected 12V batteries, or of several parallel strings of series connected batteries.

When the charge voltage of a 24V battery system increases to more than 27,3V, the Battery Balancer will turn on and compare the voltage over the two series connected batteries. The Battery Balancer will draw a current of up to 0,7A from the battery (or parallel connected batteries) with the highest voltage. The resulting charge current differential will ensure that all batteries will converge to the same state of charge.

If needed, several balancers can be paralleled.

A 48V battery bank can be balanced with three Battery Balancers.

LED indicators

Green: on (battery voltage > 27,3V)

Orange: lower battery leg active (deviation > 0,1V)

Orange: upper battery leg active (deviation > 0,1V)

Red: alarm (deviation > 0,2V). Remains on until the deviation has reduced to less than 0,14V, or until system voltage drops to less than 26,6V.

Alarm relay

Normally open. The alarm relay closes when the red LED switches on and opens when the red LED switches off.

Alarm reset

Two terminals are available to connect a push button. Interconnecting the two terminals resets the relay.

The reset condition will remain active until the alarm is over. Thereafter the relay will close again when a new alarm occurs.

Even more insight and control with the midpoint monitoring function of the BMV-702 Battery Monitor

The BMV-702 measures the midpoint of a string of cells or batteries. It displays the deviation from the ideal midpoint in volts or percent. Separate deviation percentages can be set to trigger a visual/audible alarm and to close a potential free relay contact for remote alarm purposes.

Please see the manual of the BMV-702 for more information about battery balancing.

Learn more about batteries and battery charging

To learn more about batteries and charging batteries, please refer to our book 'Energy Unlimited' (available free of charge from Victron Energy and downloadable from www.victronenergy.com).

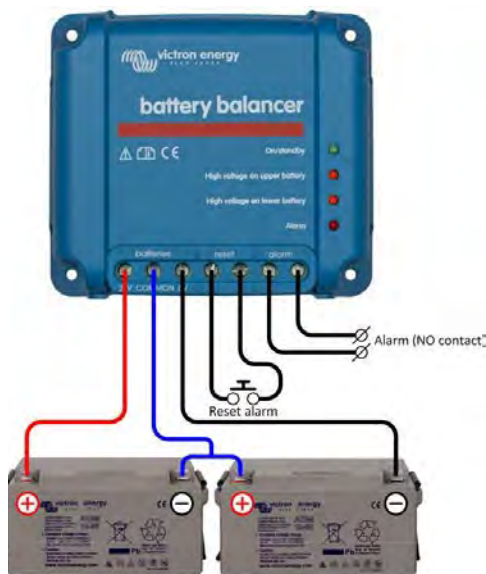

Battery Balancer connected to two series connected 12V batteries (24V system)

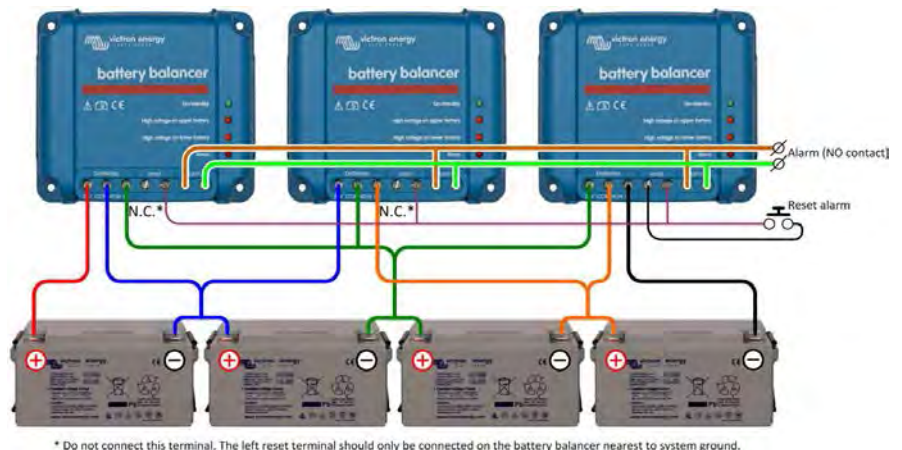

* Do not connect this terminal. The left reset terminal should only be connected on the battery balancer nearest to system ground.

Three Battery Balancers connected to four series connected 12V batteries (48V system)

Victron Battery Balancer	
Input voltage range	Up to 18V per battery, 36V total
Turn on level	27,3V +/- 1%
Turn off level	26,6V +/- 1%
Current draw when off	0,7 mA
Midpoint deviation to start balancing	50 mV
Maximum balancing current	0,7A (when deviation > 100 mV)
Alarm trigger level	200 mV
Alarm reset level	140 mV
Alarm relay	60V / 1A normally open
Alarm relay reset	Two terminals to connect a push button
Over temperature protection	yes
Operating temperature	-30 to +50°C
Humidity (non-condensing)	95%
ENCLOSURE	
Colour	Blue (RAL 5012)
Connection terminals	Screw terminals 6 mm ² / AWG10
Protection category	IP22
Weight	0,4 kg
Dimensions (h x w x d)	100 x 113 x 47 mm
STANDARDS	
Safety	EN 60950
Emission	EN 61000-6-3, EN 55014-1
Immunity	EN 61000-6-2, EN 61000-6-1, EN 55014-2
Automotive Directive	EN 50498

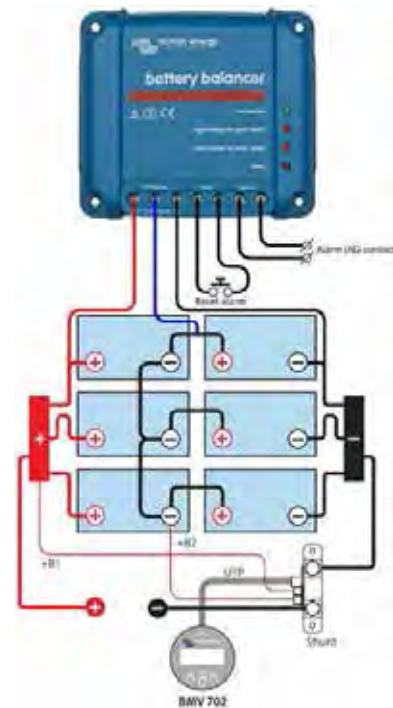

Battery Balancer connected to six series-parallel connected 12V batteries (24V system)

Installation

- The Battery Balancer(s) must be installed on a well-ventilated vertical surface close to the batteries (but, due to possible corrosive gasses, not above the batteries!)
- In case of series-parallel connection, the midpoint interconnecting cables must be sized to at least carry the current that arises when one battery becomes open-circuited.**
 - In case of 2 parallel strings: cross section 50% of the series interconnecting cables.
 - In case of 3 parallel strings: cross section 33% of the series interconnecting cables, etc.
- If required: first wire the alarm contact and the alarm reset.
- Use at least 0,75 mm² to wire the negative, positive and midpoint connections (in this order).
- The balancer is operational.
 - When the voltage over a string of two batteries is less than 26,6V the balancer switches to standby and all LEDs will be off.
 - When the voltage over a string of two batteries increases to more than 27,3V (during charging) the green LED will turn on, indicating that the balancer is on.
 - When on, a voltage deviation of more than 50 mV will start the balancing process and at 100 mV one of the two orange LEDs will turn on. A deviation of more than 200 mV will trigger the alarm relay.

What to do in case of an alarm during charging

In case of a new battery bank the alarm is probably due to differences in initial state-of-charge. If the difference between the lowest and highest battery voltage reading is more than 0,9V: stop charging and charge the individual batteries or cells separately first, or reduce charge current substantially and allow the batteries to equalize over time.

If the problem persists after several charge-discharge cycles:

- In case of series-parallel connection disconnect the midpoint parallel connection wiring and measure the individual midpoint voltages during absorption charge to isolate batteries or cells which need additional charging, or:
- Charge and then test all batteries or cells individually or:
- Connect two or more battery balancers in parallel (on average one balancer will take care of up to three parallel 200 Ah strings).

In case of an older battery bank which has performed well in the past, the problem may be due to:

- Systematic undercharge: more frequent charging needed (VRLA batteries), or equalization charge needed (flooded deep cycle flat plate or OPzS batteries). Better and regular charging will solve the problem.
- One or more faulty cells: replace all batteries.

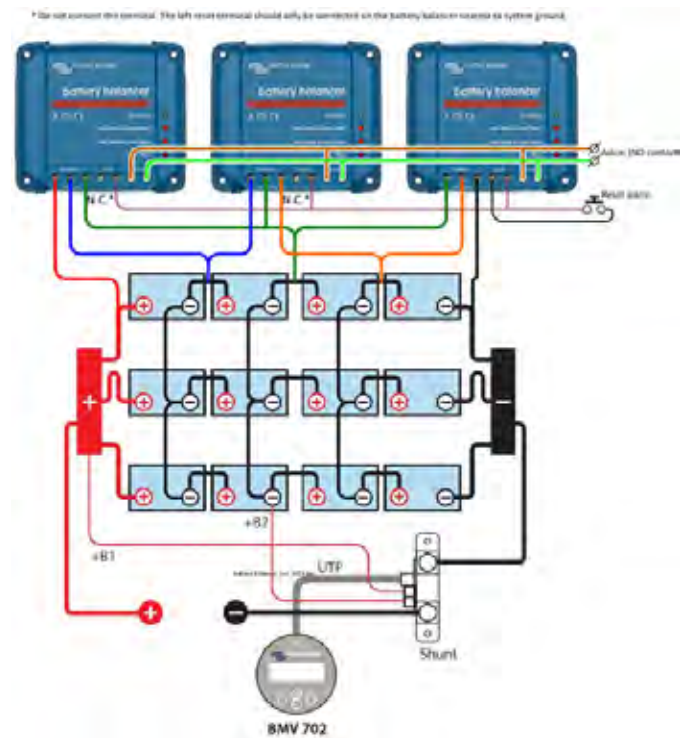

Three Battery Balancers connected to 12 series-parallel connected 12V batteries (48V system)



**AGM Battery
12V 90Ah**



GEL OPzV 2V cell

1. VRLA technology

VRLA stands for Valve Regulated Lead Acid, which means the batteries are sealed. Gas will escape through the safety valves only in case of overcharging or cell failure. VRLA batteries are maintenance free for life.

2. Sealed (VRLA) AGM Batteries

AGM stands for Absorbent Glass Mat. In these batteries the electrolyte is absorbed into a glass-fibre mat between the plates by capillary action. As explained in our book 'Energy Unlimited', AGM batteries are more suitable for short-time delivery of very high currents (engine starting) than gel batteries.

3. Sealed (VRLA) Gel Batteries

Here the electrolyte is immobilized as gel. Gel batteries in general have a longer service life and better cycle capacity than AGM batteries.

4. Low Self-Discharge

Because of the use of lead calcium grids and high purity materials, Victron VRLA batteries can be stored during long periods of time without recharge. The rate of self-discharge is less than 2% per month at 20°C. The self-discharge doubles for every increase in temperature by 10°C.

Victron VRLA batteries can therefore be stored for up to a year without recharging, if kept under cool conditions.

5. Exceptional Deep Discharge Recovery

Victron VRLA batteries have exceptional discharge recovery, even after deep or prolonged discharge. Nevertheless repeatedly deep and prolonged discharge, have a very negative effect on the service life of all lead acid batteries, Victron batteries are no exception.

6. Battery Discharging Characteristics

The rated capacity of Victron AGM and Gel Deep Cycle batteries refers to 20 hour discharge, in other words: a discharge current of 0,05 C.

The rated capacity of Victron Tubular Plate Long Life batteries refers to 10 hours discharge.

The effective capacity decreases with increasing discharge current (see table 1). Please note that the capacity reduction will be even faster in case of a constant power load, such as an inverter.

Discharge time (constant current)	End Voltage V	AGM 'Deep Cycle' %	Gel 'Deep Cycle' %	Gel 'Long Life' %
20 hours	10,8	100	100	112
10 hours	10,8	92	87	100
5 hours	10,8	85	80	94
3 hours	10,8	78	73	79
1 hour	9,6	65	61	63
30 min.	9,6	55	51	45
15 min.	9,6	42	38	29
10 min.	9,6	38	34	21
5 min.	9,6	27	24	
5 seconds		8 C	7 C	

Table 1: Effective capacity as a function of discharge time (the lowest row gives the maximum allowable 5 seconds discharge current)

Our AGM deep cycle batteries have excellent high current performance and are therefore recommended for high current applications such as engine starting. Due to their construction, Gel batteries have a lower effective capacity at high discharge currents. On the other hand, Gel batteries have a longer service life, both under float and cycling conditions.

7. Effect of temperature on service life

High temperature has a very negative effect on service life. The service life of Victron batteries as a function of temperature is shown in table 2.

Average Temperature	AGM 'Deep Cycle' years	Gel 'Deep Cycle' years	Gel 'Long Life' years
20°C / 68°F	7 - 10	12	20
30°C / 86°F	4	6	10
40°C / 104°F	2	3	5

Table 2: Design service life of Victron batteries under float service

8. Effect of temperature on capacity

As is shown by the graph below, capacity reduces sharply at low temperatures.

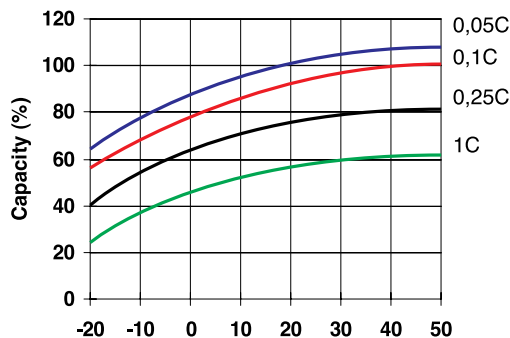

Fig. 1: Effect of temperature on capacity

9. Cycle life of Victron batteries

Batteries age due to discharging and recharging. The number of cycles depends on the depth of discharge, as is shown in figure 2.

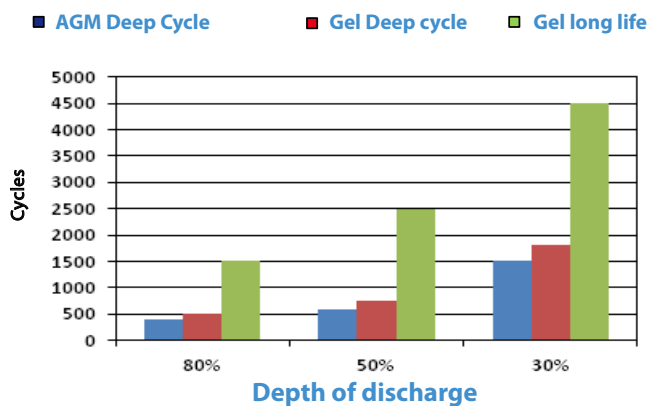

Fig. 2: Cycle life

10. Battery charging in case of cycle use: the 3-step charge curve

The most common charge curve used to charge VRLA batteries in case of cyclic use is the 3-step charge curve, whereby a constant current phase (the bulk phase) is followed by two constant voltage phases (absorption and float), see fig. 3.

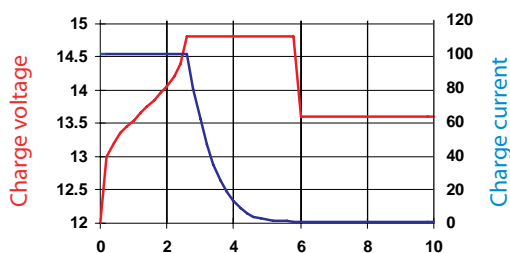

Fig. 3: Three step charge curve

During the absorption phase the charge voltage is kept at a relatively high level in order to fully recharge the battery within reasonable time. The third and last phase is the float phase: the voltage is lowered to standby level, sufficient to compensate for self-discharge.

Disadvantages of the traditional 3-step charge curve:

- During the bulk phase the current is kept at a constant and often high level, even after the gassing voltage (14,34V for a 12V battery) has been exceeded. This can lead to excessive gas pressure in the battery. Some gas will escape through the safety valves, reducing service life.
- Thereafter the absorption voltage is applied during a fixed period of time, irrespective of how deep the battery has been discharged previously. A full absorption period after a shallow discharge will overcharge the battery, again reducing service life (a.o. due to accelerated corrosion of the positive plates).
- Research has shown that battery life can be increased by decreasing float voltage to an even lower level when the battery is not in use.

11. Battery charging: longer battery life with Victron 4-step adaptive charging

Victron developed the adaptive charge curve. The 4-step adaptive charge curve is the result of years of research and testing.

The Victron four-step adaptive charge curve solves the 3 main problems of the 3-step curve:

- **Battery Safe Mode**
In order to prevent excessive gassing, Victron has invented the 'Battery Safe Mode'. The Battery Safe Mode will limit the rate of voltage increase once the gassing voltage has been reached. Research has shown that this will reduce internal gassing to a safe level.
- **Variable absorption time**
Based on the duration of the bulk stage, the charger calculates how long the absorption time should be in order to fully charge the battery. If the bulk time is short, this means the battery was already charged and the resulting absorption time will also be short, whereas a longer bulk time will also result in a longer absorption time.
- **Storage mode**
After completion of the absorption period the battery should be fully charged, and the voltage is lowered to the float or standby level. If no discharge occurs during the next 24 hours, the voltage is reduced even further and the battery goes into storage mode. The lower storage voltage reduces corrosion of the positive plates. Once every week the charge voltage is increased to the absorption level for a short period to compensate for self-discharge (Battery Refresh mode).

12. Battery charging in case of standby use: constant voltage float charging

When a battery is not frequently deeply discharged, a 2-step charge curve can be used. During the first phase the battery is charged with a limited current (the bulk phase). Once a pre-set voltage has been reached the battery is kept at that voltage (the float phase).

This charge method is used for starter batteries in vehicles and in uninterruptible power supplies (UPS).

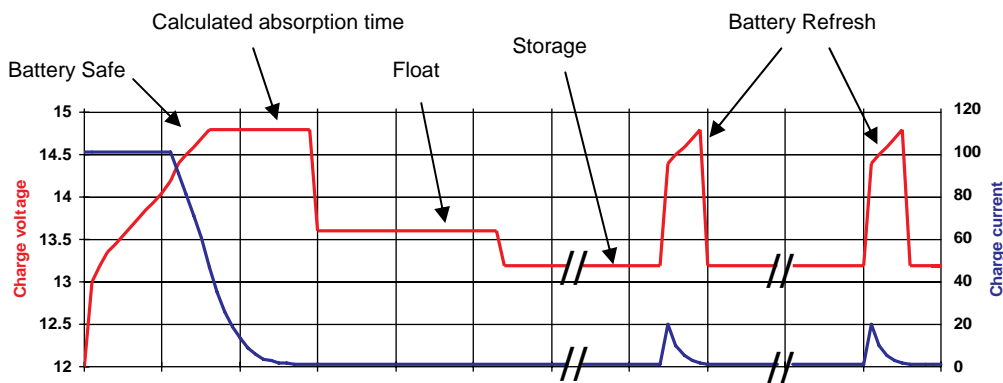

Fig. 4: Four-step adaptive charge curve

13. Optimum charge voltage of Victron VRLA batteries

The recommended charge voltage settings for a 12V battery are shown in table 3.

14. Effect of temperature on charging voltage

The charge voltage should be reduced with increased temperature. Temperature compensation is required when the temperature of the battery is expected to be less than 10°C / 50°F or more than 30°C / 85°F during long periods of time. The recommended temperature compensation for Victron VRLA batteries is -4 mV / Cell (-24 mV / °C for a 12V battery). The centre point for temperature compensation is 20°C / 70°F.

15. Charge current

The charge current should preferably not exceed 0,2C (20A for a 100Ah battery). The temperature of a battery will increase by more than 10°C if the charge current exceeds 0,2C. Therefore temperature compensation is required if the charge current exceeds 0,2C.

	Float Service (V)	Cycle service Normal (V)	Cycle service Fastest recharge (V)
Victron AGM 'Deep Cycle'			
Absorption		14,2 - 14,6	14,6 - 14,9
Float	13,5 - 13,8	13,5 - 13,8	13,5 - 13,8
Storage	13,2 - 13,5	13,2 - 13,5	13,2 - 13,5
Victron Gel 'Deep Cycle'			
Absorption		14,1 - 14,4	
Float	13,5 - 13,8	13,5 - 13,8	
Storage	13,2 - 13,5	13,2 - 13,5	
Victron Gel 'Long Life'			
Absorption		14,0 - 14,2	
Float	13,5 - 13,8	13,5 - 13,8	
Storage	13,2 - 13,5	13,2 - 13,5	

Table 3: Recommended charge voltage

12 Volt Deep Cycle AGM							General Specification
Article number	Ah	V	l x w x h mm	Weight kg	CCA @0°F	RES CAP @80°F	Technology: flat plate AGM Terminals: copper
BAT406225080	240	6	320x176x247	31	1500	480	Rated capacity: 20 hr. discharge at 25°C Float design life: 7-10 years at 20°C Cycle design life: 400 cycles at 80% discharge 600 cycles at 50% discharge 1500 cycles at 30% discharge
BAT212070080	8	12	151x65x101	2,5			
BAT212120080	14	12	151x98x101	4,1			
BAT212200080	22	12	181x77x167	5,8			
BAT412350080	38	12	197x165x170	12,5			
BAT412550080	60	12	229x138x227	20	450	90	
BAT412600080	66	12	258x166x235	24	520	100	
BAT412800080	90	12	350x167x183	27	600	145	
BAT412101080	110	12	330x171x220	32	800	190	
BAT412121080	130	12	410x176x227	38	1000	230	
BAT412151080	165	12	485x172x240	47	1200	320	
BAT412201080	220	12	522x238x240	65	1400	440	

12 Volt Deep Cycle GEL							General Specification
Article number	Ah	V	l x w x h mm	Weight kg	CCA @0°F	RES CAP @80°F	Technology: flat plate GEL Terminals: copper
BAT412550100	60	12	229x138x227	20	300	80	Rated capacity: 20 hr. discharge at 25°C Float design life: 12 years at 20°C Cycle design life: 500 cycles at 80% discharge 750 cycles at 50% discharge 1800 cycles at 30% discharge
BAT412600100	66	12	258x166x235	24	360	90	
BAT412800100	90	12	350x167x183	26	420	130	
BAT412101100	110	12	330x171x220	33	550	180	
BAT412121100	130	12	410x176x227	38	700	230	
BAT412151100	165	12	485x172x240	48	850	320	
BAT412201100	220	12	522x238x240	66	1100	440	

2 Volt Long Life GEL					General Specification
Article number	Ah	V	l x b x h mm	Weight kg	Technology: tubular plate GEL Terminals: copper
BAT702601260	600	2	145x206x688	49	Rated capacity: 10 hr. discharge at 25°C Float design life: 20 years at 20°C Cycle design life: 1500 cycles at 80% discharge 2500 cycles at 50% discharge 4500 cycles at 30% discharge
BAT702801260	800	2	210x191x688	65	
BAT702102260	1000	2	210x233x690	80	
BAT702122260	1200	2	210x275x690	93	
BAT702152260	1500	2	210x275x840	115	
BAT702202260	2000	2	215x400x815	155	
BAT702252260	2500	2	215x490x815	200	
BAT702302260	3000	2	215x580x815	235	

Other capacities and terminal types: at request

Why lithium-iron-phosphate?

Lithium-iron-phosphate (LiFePO₄ or LFP) is the safest of the mainstream li-ion battery types. The nominal voltage of a LFP cell is 3,2V (lead-acid: 2V/cell). A 12,8V LFP battery therefore consists of 4 cells connected in series; and a 25,6V battery consists of 8 cells connected in series.



12,8V 90Ah LiFePO₄ Battery



**12,8V 300Ah LiFePO₄ Battery
(only one data cable shown)**

Rugged

A lead-acid battery will fail prematurely due to sulfation:

- If it operates in deficit mode during long periods of time (i.e. if the battery is rarely, or never at all, fully charged).
- If it is left partially charged or worse, fully discharged (yacht or mobile home during wintertime).

A LFP battery does not need to be fully charged. Service life even slightly improves in case of partial charge instead of a full charge. This is a major advantage of LFP compared to lead-acid.

Other advantages are the wide operating temperature range, excellent cycling performance, low internal resistance and high efficiency (see below).

LFP is therefore the chemistry of choice for very demanding applications.

Efficient

In several applications (especially off-grid solar and/or wind), energy efficiency can be of crucial importance. The round trip energy efficiency (discharge from 100% to 0% and back to 100% charged) of the average lead-acid battery is 80%.

The round trip energy efficiency of a LFP battery is 92%.

The charge process of lead-acid batteries becomes particularly inefficient when the 80% state of charge has been reached, resulting in efficiencies of 50% or even less in solar systems where several days of reserve energy is required (battery operating in 70% to 100% charged state).

In contrast, a LFP battery will still achieve 90% efficiency under shallow discharge conditions.

Size and weight

Saves up to 70% in space

Saves up to 70% in weight

Expensive?

LFP batteries are expensive when compared to lead-acid. But in demanding applications, the high initial cost will be more than compensated by longer service life, superior reliability and excellent efficiency.

Endless flexibility

LFP batteries are easier to charge than lead-acid batteries. The charge voltage may vary from 14 V to 16 V (as long as no cell is subjected to more than 4,2 V), and they do not need to be fully charged. Therefore several batteries can be connected in parallel and no damage will occur if some batteries are less charged than others.

With or without Battery Management System (BMS)?

Important facts:

1. A LFP cell will fail if the voltage over the cell falls to less than 2,5V (note: recovery by charging with a low current, less than 0,1C, is sometimes possible).

2. A LFP cell will fail if the voltage over the cell increases to more than 4,2V.

Lead-acid batteries will eventually also be damaged when discharged too deeply or overcharged, but not immediately. A lead-acid battery will recover from total discharge even after it has been left in discharged state during days or weeks (depending on battery type and brand).

3. The cells of a LFP battery do not auto-balance at the end of the charge cycle.

The cells in a battery are not 100% identical. Therefore, when cycled, some cells will be fully charged or discharged earlier than others. The differences will increase if the cells are not balanced/equalized from time to time.

In a lead-acid battery a small current will continue to flow even after one or more cells are fully charged (the main effect of this current is decomposition of water into hydrogen and oxygen). This current helps to fully charge other cells that are lagging behind, thus equalizing the charge state of all cells.

The current which flows through a fully-charged LFP cell however, is nearly zero, and lagging cells will therefore not be fully charged. Over time the differences between cells may become so extreme that, even though the overall battery voltage is within limits, some cells will fail due to over- or under voltage. Cell balancing is therefore highly recommended.

In addition to cell balancing, a BMS will:

- Prevent cell under voltage by timely disconnecting the load.
- Prevent cell overvoltage by reducing charge current or stopping the charge process.
- Shut down the system in case of over temperature.

A BMS is therefore indispensable to prevent damage to Li-ion batteries.

Our LFP batteries have integrated cell balancing and cell monitoring. Up to ten batteries can be paralleled and up to four batteries can be series connected, so that a 48V battery bank of up to 3000Ah can be assembled. The cell balancing/monitoring cables can be daisy-chained and must be connected to a Battery Management System (BMS).

Battery Management System (BMS)

The BMS will:

1. Disconnect or shut down the load whenever the voltage of a battery cell falls to less than 2,5V.
2. Stop the charging process whenever the voltage of a battery cell increases to more than 4,2V.
3. Shut down the system whenever the temperature of a cell exceeds 50°C.

More features may be included: see the individual BMS datasheets.

Battery specification					
VOLTAGE AND CAPACITY	LFP-BMS 12,8/60	LFP-BMS 12,8/90	LFP-BMS 12,8/160	LFP-BMS 12,8/200	LFP-BMS 12,8/300
Nominal voltage	12,8V	12,8V	12,8V	12,8V	12,8V
Nominal capacity @ 25°C*	60Ah	90Ah	160Ah	200Ah	300Ah
Nominal capacity @ 0°C*	48Ah	72Ah	130Ah	160Ah	240Ah
Nominal capacity @ -20°C*	30Ah	45Ah	80Ah	100Ah	150Ah
Nominal energy @ 25°C*	768Wh	1152Wh	2048Wh	2560Wh	3840Wh
*Discharge current ≤1C					
CYCLE LIFE (capacity ≥ 80% of nominal)					
80% DoD	2500 cycles				
70% DoD	3000 cycles				
50% DoD	5000 cycles				
DISCHARGE					
Maximum continuous discharge current	180A	270A	400A	500A	750A
Recommended continuous discharge current	≤60A	≤90A	≤160A	≤200A	≤300A
Maximum 10 s pulse current	600A	900A	1200A	1500A	2000A
End of discharge voltage	11V	11V	11V	11V	11V
OPERATING CONDITIONS					
Operating temperature	-20°C to +50°C (maximum charge current when battery temperature < 0°C: 0,05C, i.e. 10A in case of a 200Ah battery)				
Storage temperature	-45°C to +70°C				
Humidity (non-condensing)	Max. 95%				
Protection class	IP 54				
CHARGE					
Charge voltage	Between 14V and 15V (<14,5V recommended)				
Float voltage	13,6V				
Maximum charge current	180A	270A	400A	500A	750A
Recommended charge current	≤30A	≤45A	≤80A	≤100A	≤150A
OTHER					
Max storage time @ 25°C*	1 year				
BMS connection	Male + female cable with M8 circular connector, length 50cm				
Power connection (threaded inserts)	M8	M8	M10	M10	M10
Dimensions (h x w x d) mm	235x293x139	249x293x168	320x338x233	295x425x274	345x425x274
Weight	12kg	16kg	33kg	42kg	51kg
*When fully charged					



**Telecom Battery
Battery AGM 12V 200Ah**

Designed for telecom applications; excellent 'floor space savers' for marine and vehicle applications

The deep cycle AGM telecom series has been designed for use in telecom systems. With front access terminals and small footprint, the batteries are ideal for racked systems. Similarly, these batteries can help solve limited floor space and access problems on board boats and vehicles.

AGM technology

AGM stands for Absorbent Glass Mat. In these batteries the electrolyte is absorbed into a glass-fibre mat between the plates by capillary action.

Low self-discharge

Because of the use of lead calcium grids and high purity materials, Victron VRLA batteries can be stored during long periods of time without recharge. The rate of self-discharge is less than 2% per month at 20°C. The self-discharge doubles for every increase in temperature by 10°C.

Low internal resistance

Accepts very high charge and discharge rates.

High cyclic life capability

More than 500 cycles at 50% depth of discharge.

Learn more about batteries and battery charging

To learn more about batteries and charging batteries, please refer to our book 'Energy Unlimited' (available free of charge from Victron Energy and downloadable from www.victronenergy.com).



**Telecom Battery
Battery AGM 12V 200Ah**

12V AGM Telecom battery	115Ah	165Ah	200Ah
Capacity 1 / 3 / 5 / 10 / 20 hours (% of nominal)	60 / 75 / 82 / 91 / 100 (@ 70°F/25°C, end of discharge 10,5V)		
Capacity 10 / 20 / 30 / 40 minutes (% of nominal)	33 / 44 / 53 / 57 (@ 70°F/25°C, end of discharge 9,6V)		
Nominal capacity (77°F/25°C, 10,5V)	115Ah	165Ah	200Ah
Cold Cranking Amps @ 0°F/-18°C	1000	1500	1800
DIN cold start current (A) @ 0°F/-18°C	600	900	1000
Short Circuit Current (A)	3500	5000	6000
Reserve Capacity (minutes)	200	320	400
Shelf life @ 70°F/20°C	1 year		
Absorption voltage (V) @ 70°F/20°C	14,4 – 14,7		
Float voltage (V) @ 70°F/20°C	13,6 – 13,8		
Storage voltage (V) @ 70°F/20°C	13,2		
Float design life @ 70°F/20°C	12 years		
Cycle design life @ 80% discharge	500		
Cycle design life @ 50% discharge	750		
Cycle design life @ 30% discharge	1800		
Dimensions (l x w x h, mm)	395 x 110 x 293mm	548 x 105 x 316mm	546 x 125 x 323mm
Dimensions (l x w x h, inches)	15.37 x 4.33 x 11.53	21.57 x 4.13 x 12.44	21.49 x 4.92 x 12.71
Weight (kg/pounds)	35kg/77lbs	49kg/88lbs	60kg/132lbs

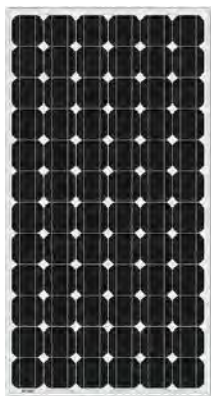

- Low voltage-temperature coefficient enhances high-temperature operation.
- Exceptional low-light performance and high sensitivity to light across the entire solar spectrum.
- 25-Year limited warranty on power output and performance.
- 5-Year limited warranty on materials and workmanship.
- Sealed, waterproof, multi-functional junction box gives high level of safety.
- High performance bypass diodes minimize the power drop caused by shade.
- Advanced EVA (Ethylene Vinyl Acetate) encapsulation system with triple-layer back sheet meets the most stringent safety requirements for high-voltage operation.
- A sturdy, anodized aluminium frame allows modules to be easily roof-mounted with a variety of standard mounting systems.
- Highest quality, high-transmission tempered glass provides enhanced stiffness and impact resistance.
- High power models with pre wired quick-connect system with MC4 (PV-ST01) connectors.

BlueSolar Monocrystalline 280W



MC4 connectors

Article Number	Description	Weight	Electrical data under STC ⁽¹⁾				
			Nominal Power	Max-Power Voltage	Max-Power Current	Open-Circuit Voltage	Short-Circuit Current
			P _{MPP}	V _{MPP}	I _{MPP}	V _{oc}	I _{sc}
		Kg	W	V	A	V	A
SPM030301200	30W-12V Mono 430x545x25mm series 3a	2.5	30	18	1.67	22.5	2
SPM030501200	50W-12V Mono 630x545x25mm series 3a	4	50	18	2.78	22.2	3.16
SPM030801200	80W-12V Mono 1195x545x35mm series 3a	8	80	18	4.45	22.3	4.96
SPM031001200	100W-12V Mono 1195x545x35mm series 3a	8	100	18	5.56	22.4	6.53
SPM031301200	130W-12V Mono 1480x673x35mm series 3a	12	130	18	7.23	22.4	8.49
SPM031902400	190W-24V Mono 1580x808x35mm series 3a	15	190	36	5.44	43.2	5.98
SPM033002400	300W-24V Mono 1956x992x45mm series 3a	24	300	36	8.06	45.5	8.56

Module	SPM 030301200	SPM 030501200	SPM 030801200	SPM 031001200	SPM 031301200	SPM 031902400	SPM 033002400
Nominal Power (±3% tolerance)	30W	50W	80W	100W	130W	190W	300W
Cell type	Monocrystalline						
Number of cells in series	36					72	
Maximum system voltage (V)	1000 V						
Temperature coefficient of P _{MPP} (%)	-0.48/°C	-0.48/°C	-0.48/°C	-0.48/°C	-0.48/°C	-0.48/°C	-0.48/°C
Temperature coefficient of V _{oc} (%)	-0.34/°C	-0.34/°C	-0.34/°C	-0.34/°C	-0.34/°C	-0.34/°C	-0.34/°C
Temperature coefficient of I _{sc} (%)	+0.037/°C	+0.037/°C	+0.037/°C	+0.037/°C	+0.05/°C	+0.037/°C	+0.037/°C
Temperature Range	-40°C to +85°C						
Surface Maximum Load Capacity	200 kg/m ²						
Allowable Hail Load	23 m/s, 7.53 g						
Junction Box Type	PV-LH0801		PV-LH0808			PV-JB002	
Length of Cables / Connector Type	No cable	No cable	900 mm MC4				
Output tolerance	+/-3%						
Frame	Aluminium						
Product warranty	5 years						
Warranty on electrical performance	10 years 90% + 25 years 80% of power output						
Smallest packaging unit	1 panel						
Quantity per pallet	100		40		20		18

1) STC (Standard Test Conditions): 1000 W/m², 25°C, AM (Air Mass) 1.5





BlueSolar Polycrystalline 140W

- Low voltage-temperature coefficient enhances high-temperature operation.
- Exceptional low-light performance and high sensitivity to light across the entire solar spectrum.
- 25-Year limited warranty on power output and performance.
- 5-Year limited warranty on materials and workmanship.
- Sealed, waterproof, multi-functional junction box gives high level of safety.
- High performance bypass diodes minimize the power drop caused by shade.
- Advanced EVA (Ethylene Vinyl Acetate) encapsulation system with triple-layer back sheet meets the most stringent safety requirements for high-voltage operation.
- A sturdy, anodized aluminium frame allows modules to be easily roof-mounted with a variety of standard mounting systems.
- Highest quality, high-transmission tempered glass provides enhanced stiffness and impact resistance.
- High power models with pre wired quick-connect system with MC4 (PV-ST01) connectors.



MC4 connectors

Article Number	Description	Net weight	Electrical data under STC ⁽¹⁾				
			Nominal Power	Max-Power Voltage	Max-Power Current	Open-Circuit	Short-Circuit Current
			PMPP	VMPP	IMPP	Voc	Isc
		Kg	W	V	A	V	A
SPP030201200	20W-12V Poly 480x350x25 mm series 3a	2.2	20	18	1.11	22.5	1.23
SPP030301200	30W-12V Poly 410x670x25 mm series 3a	3.7	30	18	1.67	22.5	1.85
SPP020401200	40W-12V Poly 670x475x25 mm series 2a	4.2	40	18	2.22	22.5	1.85
SPP030501200	50W-12V Poly 540x670x25 mm series 3a	4.3	50	18	2.78	22.2	3.09
SPP020751200	75W-12V Poly 780x670x25 mm series 2a	6.6	75	18	4.17	22.2	4.64
SPP030801200	80W-12V Poly 840x670x35 mm series 3a	6.8	80	18	4.44	21.6	5.06
SPP031001200	100W-12V Poly 1000x670x35 mm series 3a	8.9	100	18	5.56	21.6	6.32
SPP031401200	140W-12V Poly 1480x673x35 mm series 3a	12	140	20	7.78	21.6	8.85
SPP032502400	250W-20V Poly 1650x992x40 mm series 3a	18	250	30	8.33	36.01	9.40
SPP032902400	290W-24V Poly 1956x992x45 mm series 3a	24	290	36	8.06	44,10	8.56

Module	SPP 030201200	SPP 030301200	SPP 020401200	SPP 030501200	SPP 020751200	SPP 030801200	SPP 031001200	SPP 031401200	SPP 032502400	SPP 032902400
Nominal Power (± 3% tolerance)	20W	30W	40W	50W	75W	80W	100W	140W	250W	290W
Cell type	Polycrystalline									
Number of cells in series	36						40	60	72	
Maximum system voltage (V)	1000V									
Temperature coefficient of PMPP (%)	-0.47/°C	-0.48/°C		-0.48/°C		-0.48/°C		-0.47/°C		-0.47/°C
Temperature coefficient of Voc (%)	-0.34/°C	-0.34/°C		-0.34/°C		-0.35/°C		-0.34/°C		-0.34/°C
Temperature coefficient of Isc (%)	+0.045/°C	+0.037/°C		+0.037/°C		+0.037/°C		+0.037/°C		+0.045/°C
Temperature Range	-40°C to +85°C									
Surface Maximum Load Capacity	200 kg/m ²									
Allowable Hail Load	23 m/s, 7.53 g									
Junction Box Type	PV-LH0801				PV-JH02	PV-LH0808			PV-JB002	
Length of Cable / connector	No cable	No cable	No cable	No cable	900 mm / MC4					
Output tolerance	+/-3%									
Frame	Aluminium									
Product warranty	5 years									
Warranty on electrical performance	10 years 90% + 25 years 80% of power output									
Smallest packaging unit	1 panel									
Quantity per pallet	150	100			20			19	18	

1) STC (Standard Test Conditions): 1000 W/m², 25°C, AM (Air Mass) 1.5

BlueSolar charge controllers - overview

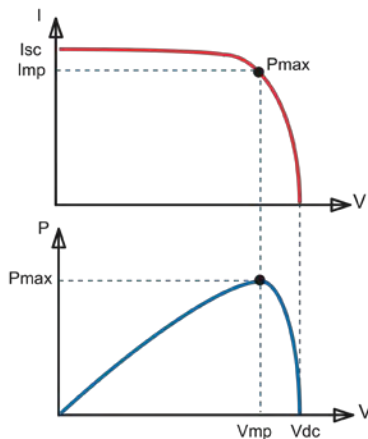

Maximum Power Point Tracking

Upper curve:

Output current (I) of a solar panel as function of output voltage (V). The Maximum Power Point (MPP) is the point Pmax along the curve where the product $I \times V$ reaches its peak.

Lower curve:

Output power $P = I \times V$ as function of output voltage. When using a PWM (not MPPT) controller the output voltage of the solar panel will be nearly equal to the voltage of the battery, and will be lower than V_{mp} .

Feature highlights

- Ultra-fast Maximum Power Point Tracking (MPPT)
- Advanced Maximum Power Point Detection in case of partial shading conditions
- Load output on the small models
- Battery Life: intelligent battery management by load shedding
- Automatic battery voltage recognition
- Flexible charge algorithm
- Over-temperature protection and power de-rating when temperature is high.

Color Control GX

All Victron Energy MPPT Charge Controllers are compatible with the Color Control GX: The Color Control GX provides intuitive control and monitoring for all products connected to it. The list of Victron products that can be connected is endless: Inverters, Multis, Quattros, MPPT 150/70, BMV-600 series, BMV-700 series, Skylla-i, Lynx Ion and even more.

VRM Online Portal

Besides monitoring and controlling products on the Color Control GX, the information is also forwarded to our free remote monitoring website: the VRM Online Portal. To get an impression of the VRM Online Portal, visit <https://vrm.victronenergy.com>, and use the 'Take a look inside' button. The portal is free of charge.

Related product: EasySolar

Minimal wiring and an all-in-one solution: the EasySolar takes power solutions one stage further, by combining an Ultra-fast BlueSolar charge controller (MPPT), an inverter/charger and AC distribution in one enclosure.

Model	Load output	Fan	Battery voltage	Display	Color Control GX	Com. port
75/10	Yes	No	12/24	No	Compatible	VE.Direct
75/15	Yes	No	12/24	No	Compatible	VE.Direct
100/15	Yes	No	12/24	No	Compatible	VE.Direct
100/30	No	No	12/24	No	Compatible	VE.Direct
100/50	No	No	12/24	No	Compatible	VE.Direct
150/35	No	No	12/24/36/48	No	Compatible	VE.Direct
150/45-Tr	No	No	12/24/36/48	No	Compatible	VE.Direct
150/45-MC4	No	No	12/24/36/48	No	Compatible	VE.Direct
150/60-Tr	No	No	12/24/36/48	No	Compatible	VE.Direct
150/60-MC4	No	No	12/24/36/48	No	Compatible	VE.Direct
150/70-Tr	No	No	12/24/36/48	No	Compatible	VE.Direct
150/70-MC4	No	No	12/24/36/48	No	Compatible	VE.Direct
150/70	No	No	12/24/36/48	Yes	Compatible	VE.Can
150/85	No	Yes	12/24/36/48	Yes	Compatible	VE.Can



BlueSolar charge controller MPPT 75/10, 75/15 & MPPT 100/15

Solar Charge Controller
MPPT 75/15**Ultra-fast Maximum Power Point Tracking (MPPT)**

Especially in case of a clouded sky, when light intensity is changing continuously, an ultra-fast MPPT controller will improve energy harvest by up to 30% compared to PWM charge controllers and by up to 10% compared to slower MPPT controllers.

Load output

Over-discharge of the battery can be prevented by connecting all loads to the load output. The load output will disconnect the load when the battery has been discharged to a pre-set voltage.

Alternatively, an intelligent battery management algorithm can be chosen: see Battery Life.

The load output is short circuit proof.

Some loads (especially inverters) can best be connected directly to the battery, and the inverter remote control connected to the load output. A special interface cable may be needed, please see the manual.

Battery Life: intelligent battery management

When a solar charge controller is not able to recharge the battery to its full capacity within one day, the result is often that the battery will continually be cycled between a 'partially charged' state and the 'end of discharge' state. This mode of operation (no regular full recharge) will destroy a lead-acid battery within weeks or months.

The Battery Life algorithm will monitor the state of charge of the battery and, if needed, day by day slightly increase the load disconnect level (i.e. disconnect the load earlier) until the harvested solar energy is sufficient to recharge the battery to nearly the full 100%. From that point onwards the load disconnect level will be modulated so that a nearly 100% recharge is achieved about once every week.

Programmable battery charge algorithm

See the software section on our website for details

Day/night timing and light dimming option

See the software section on our website for details

Programming, real-time data and history display options

- Modern Apple and Android smartphones, tablets, macbooks and other devices: see the VE.Direct Bluetooth Smart dongle and the MPPT app discovery sheet for screenshots.
- ColorControl panel

BlueSolar Charge Controller	MPPT 75/10	MPPT 75/15	MPPT 100/15
Battery voltage	12/24V Auto Select		
Rated charge current	10A	15A	15A
Maximum PV power, 12V 1a,b)	135W	200W	200W
Maximum PV power, 24V 1a,b)	270W	400W	400W
Automatic load disconnect	Yes, maximum load 15A		
Maximum PV open circuit voltage	75V	100V	
Peak efficiency	98%		
Self-consumption	10 mA		
Charge voltage 'absorption'	14,4V / 28,8V (adjustable)		
Charge voltage 'float'	13,8V / 27,6V (adjustable)		
Charge algorithm	multi-stage adaptive		
Temperature compensation	-16 mV / °C resp. -32 mV / °C		
Continuous/peak load current	15A / 50A		
Low voltage load disconnect	11,1V / 22,2V or 11,8V / 23,6V or Battery Life algorithm		
Low voltage load reconnect	13,1V / 26,2V or 14V / 28V or Battery Life algorithm		
Protection	Battery reverse polarity (fuse) Output short circuit / Over temperature		
Operating temperature	-30 to +60°C (full rated output up to 40°C)		
Humidity	95%, non-condensing		
Data communication port	VE.Direct See the data communication white paper on our website		
ENCLOSURE			
Colour	Blue (RAL 5012)		
Power terminals	6 mm ² / AWG10		
Protection category	IP22 (connection area)		
Weight	0,5 kg		
Dimensions (h x w x d)	100 x 113 x 40 mm		
STANDARDS			
Safety	EN/IEC 62109		

1a) If more PV power is connected, the controller will limit input power to the stated maximum.

1b) PV voltage must exceed Vbat + 5V for the controller to start.

Thereafter minimum PV voltage is Vbat + 1V

MultiPlus principle

Inverter/charger system with intelligent shore and generator power management

PowerControl: Dealing with limited generator or grid power all models in the MultiPlus range feature powerful battery chargers. When the largest model is working hard it can draw almost 10A from a 230V supply. Using the remote panel it is possible to 'dial-in' the maximum current that is available from mains or generator. The MultiPlus will then automatically regulate the charger taking account of other system AC loads and ensuring the charger only uses what is spare. This way it is possible to avoid tripping the mains power or overloading the generator.

Power control ©

Battery charger reduces its output, if required, to avoid overload of supply when system consumption is high.

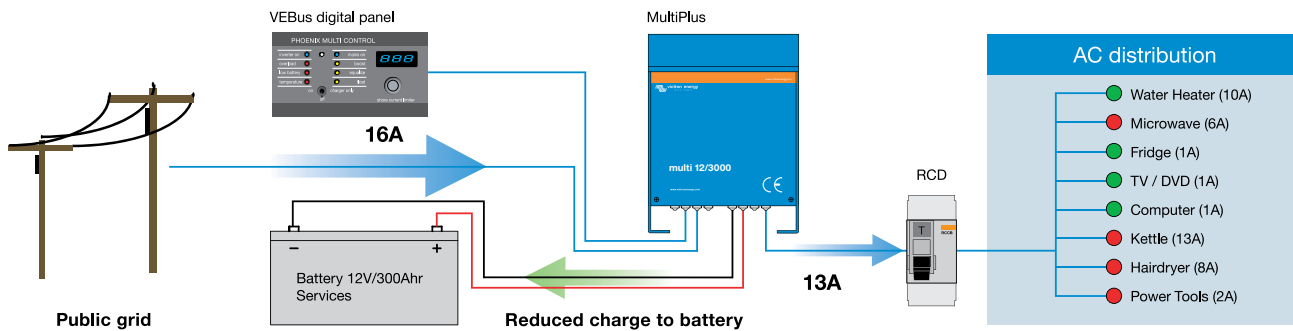

PowerAssist: Boosting the power available from mains or generator, an innovative feature of MultiPlus. The feature that most distinguishes the MultiPlus from other inverter/chargers is PowerAssist. This feature takes the principle of PowerControl to a further dimension by allowing a MultiPlus to supplement the power available from mains or generator to 'assist' during periods of high demand. Peak power demand is almost always sustained only for short periods, either a few minutes (in the case of items like cooking appliances) or just a few seconds (in the case of the burst of energy needed to start an air-conditioning or refrigeration compressor).

With the capacity of the generator or mains power set on the remote panel, the MultiPlus detects when the load is becoming too much for the supply and will instantly provide the extra power required. When the demand has reduced, the unit returns to charging the battery. This feature is equally effective in large and small systems helping to reduce the required generator capacity or to achieve greater things with limited mains power. There is even a special feature to enable the MultiPlus/Quattro to work perfectly with portable generators.

Power assist ©

Inverter boosts incoming power, if required, to avoid overload of supply when system consumption exceeds supply.

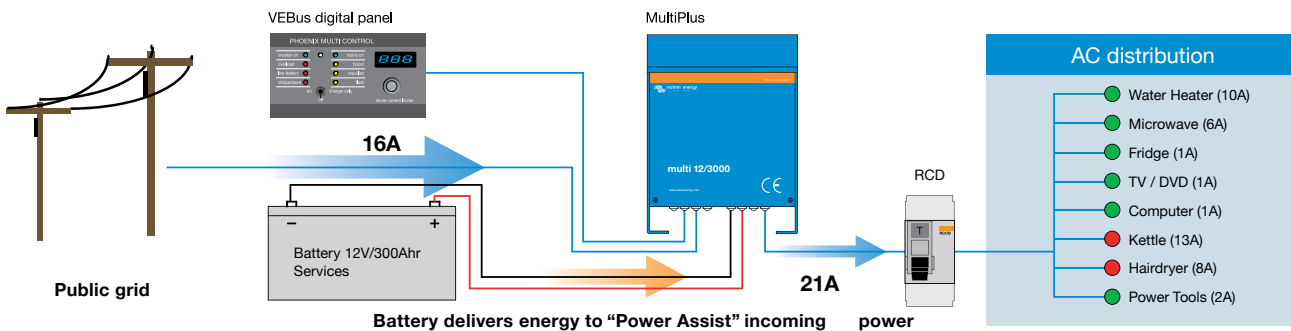

Comfort system

Appliance	System
Lighting	Quattro 12/3000/120
Communication & navigation	BMV602-5 battery monitor
Water heater	2x12V/200AH and 1X80AH batteries
Microwave oven	Digital control remote panel
2 ring introduction hob	Alternator 12/150
Coffee machine/Kettle	DC Link Box
TV/DVD	Isolation transformer
Laptop	Cyrix battery separator
Small chargers (mobile phone, shaver etc.)	
Refrigerator and freezer	Solarpanel and MPPT Solar charger

Comfort Plus system

Appliance	System
Lighting	2 x Quattro 24/5000/120
Communication & navigation	VE-NET Battery controller
Water heater	4x12V/200AH and 1X80AH batteries
Electric gallery with 4 ring induction hob, microwave/combi oven, refrigerator, freezer, washer/dryer	Blue Power panel
Coffee machine and kettle	Alternator 12/150
TV/DVD	DC Link box
Multimedia PC	Isolation transformers
Small chargers (mobile phone, shaver etc.)	
Modest air-conditioning	Solarpanel and MPPT Solar charger

Comfort system - 7 kVa (30a) capacity

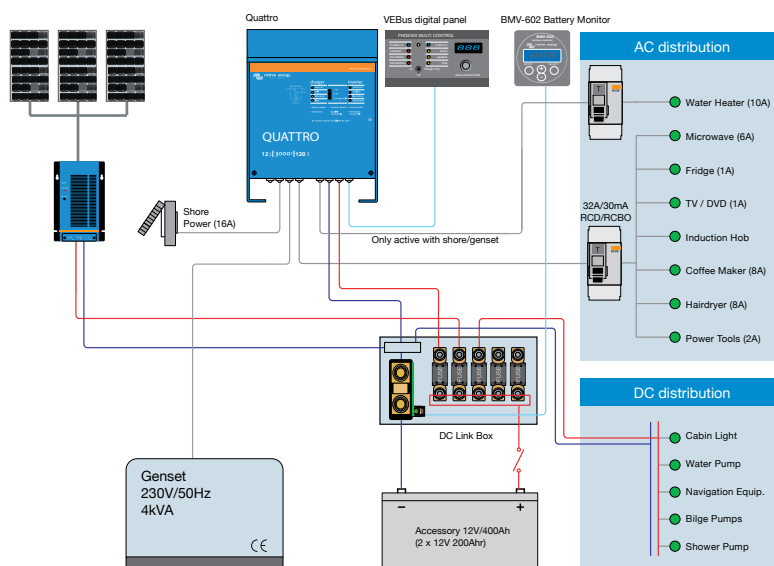

Comfort plus system - 25 kVa capacity

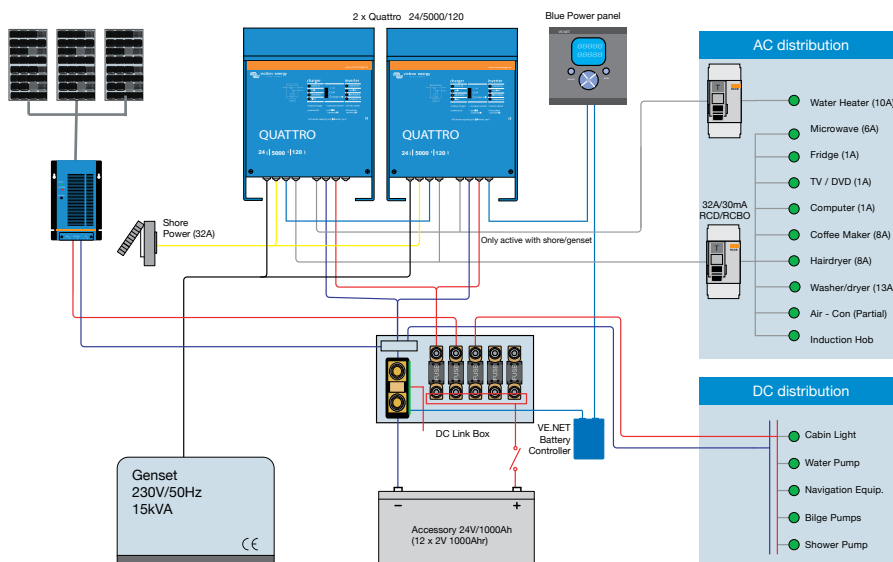

About Victron Energy

With over 40 years of experience, Victron Energy enjoys an unrivalled reputation for technical innovation, reliability and quality. Victron is a world leader in the supply of self-supporting electrical power. Our products have been designed to meet the most demanding situations faced by a diversity of craft, recreational and commercial alike. Victron's ability to meet the demand for customized off-grid systems is unprecedented. Our product range includes sine wave inverters and inverterchargers, battery chargers, DC/DC converters, transfer switches, gel and AGM batteries, alternators, battery monitors, solar charge regulators, solar panels, complete network solutions and many other innovative solutions.

World-wide service and support

Having served the off-grid, industrial and vehicle markets as well as both the commercial and leisure marine sectors for over 40 years, Victron has an established network of dealers and distributors covering the whole world. Our customer base is such that providing prompt and competent local service is essential.

This is reflected in the capabilities of our support network. Our flexible approach to service support and our commitment to quick turnaround for repairs is marketleading. There are countless examples of Victron products that have provided for decades of reliable service in the most demanding applications. This level of reliability combined with the highest level of technical know-how results in Victron Energy power systems that offer the very best value available.



Firefighter truck in action, Germany



