

RFA-C Flameproof Core Immersion Heaters

The RFA-C range of flameproof core removable cartridge heaters offers a hazardous area heating solution for oil and similar applications where low heat density is required. The element can be withdrawn for inspection without system drain down. The standard heater consists of a single element core fitted into a mounting flange. A robust flameproof terminal enclosure protects the electrical connections. The watts density of the element core fitted depends upon the media to be heated and the kilowatt rating required.



FEATURES

- Certified to meet the ATEX Equipment Directive
- Lightweight cast aluminium alloy terminal enclosure with weatherproof protection to IP66 and IP67
- Choice of built in process temperature sensors
- Suitable for ambient temperatures from -40°C to $+40^{\circ}\text{C}$
- Mounting of the heater can be by threaded boss or an industry standard flange
- Designed for horizontal installation only, vertical mounting version available on request
- Can be supplied with the terminal box mounted away from the fixing boss/flange for high process temperatures

TYPICAL APPLICATIONS

- Pre-heating oil and water
- Processing equipment
- Cleaning and rinsing tanks
- Heat transfer systems
- Boiler equipment
- Frost protection
- Compressors
- Turbines
- Oil sumps
- Lube oil reservoirs
- Oil separators

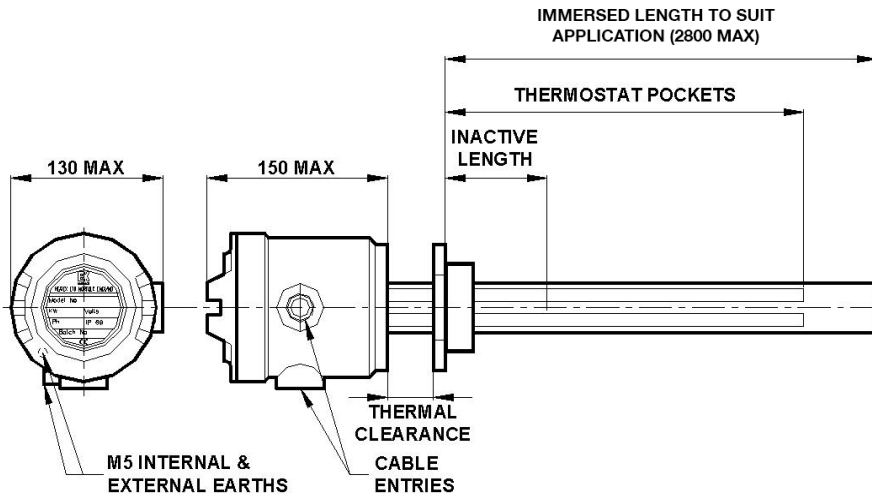
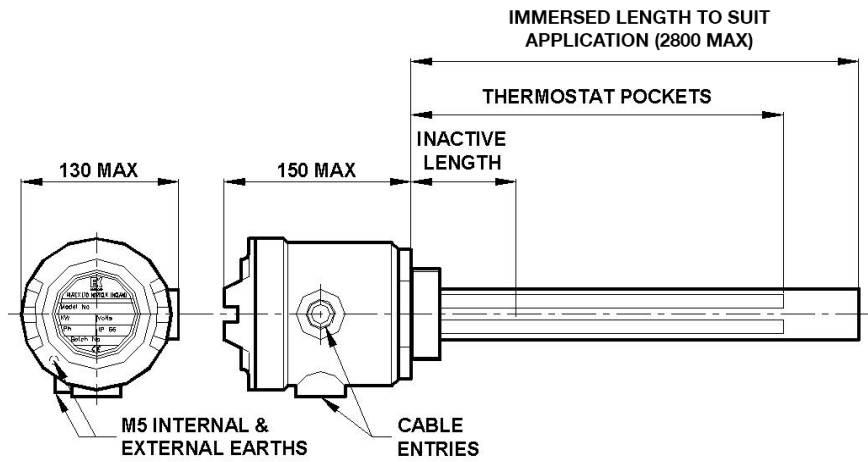

Certifications

ATEX  II 2 G
Ex d IIC T3 to T6 Gb Zone 1 and 2
CU TR (formerly GOST)

Enclosure

Cast aluminium alloy with a maximum of two cable entries, external and internal earths, screwed terminal cover, finished in epoxy paint

Elements

Removable core, comprising high quality 80/20 nickel chrome resistance wire, contained within ceramic formers

Element

A choice of carbon steel, or 316L stainless steel secured by either brazing or welding depending upon the process application

Controls

Heater over-temperature protection is fitted as standard

Mounting

Any threaded boss or flange in any material can be specified within the limits of the design parameters. Heaters can be either 'direct-on' or 'stand-off'

Rating

Maximum loading 8kW

Voltage

Any electrical supply up to 690V